

Apr. 2008



SERVICE MANUAL ADDENDUM

IC-F3060 IC-F3160 series

CONTENTS

PARTS LIST	1
BOARD LAYOUTS	13
VOLTAGE DIAGRAM	17

[FRONT-A UNIT] (for F3160 series)

REF NO.	PARTS NO.	DESCRIPTION	M.	H/V LOCATION
IC501	1180002401	S.REG S-812C30AMC-C2K-G	B	66.7/35.7
IC505	1110007330	S.IC M62320FP-DF5G	B	74/36.8
IC506	1110007330	S.IC M62320FP-DF5G	B	56.8/24.5
IC508	1110006770	S.IC TDA8547TS/N	B	79.6/11.9
IC509	1110007010	S.IC NJM12904R	B	79.8/24.9
Q501	1520000460	S.TR 2SB1132 T100 R	B	75.2/25
Q502	1590001190	S.TR XP6501-(TX) .AB	B	75.8/20.8
Q506	1590003230	S.TR UNR9113J-(TX)	B	83.6/41
Q507	1590003290	S.TR UNR9213J-(TX)	B	72.3/6.1
Q508	1590001330	S.TR DTA114EUA T106	B	72.2/9
Q509	1590000980	S.TR DTB123EK T146	B	72.4/12.3
Q512	1590003290	S.TR UNR9213J-(TX)	B	72/18
Q513	1590003290	S.TR UNR9213J-(TX)	B	74.9/15.6
Q515	1560001360	S.FET 2SK3019 TL	B	81/32.2
Q516	1590003290	S.TR UNR9213J-(TX)	B	80.9/36
Q517	1590003290	S.TR UNR9213J-(TX)	B	56.7/9
D504	1790001250	S.DIO MA2S111-(TX)	B	71/25.1
D505	1160000140	S.DIO DAP222 TL	B	63.6/21.9
D506	1160000140	S.DIO DAP222 TL	B	63.6/26
D508	1160000060	S.DIO DAN202U T106	B	75.1/5.7
D509	1730002350	S.ZEN MA8110-M (TX)	B	56.1/11.1
	1790001280	S.DIO MA111 (TX)	B	Except [EUR] [F3161DT/DS]
R503	7030009140	S.RES ERJ2GEJ 272 X (2.7 k)	B	74/20
R504	7030008290	S.RES ERJ2GEJ 183 X (18 k)	B	74.8/18.4
R505	7030005120	S.RES ERJ2GEJ 102 X (1 k)	B	76.6/18.4
R506	7030005120	S.RES ERJ2GEJ 102 X (1 k)	B	75.2/13.7
R508	7030005050	S.RES ERJ2GEJ 103 X (10 k)	B	81.8/18.2
R509	7030005050	S.RES ERJ2GEJ 103 X (10 k)	B	79.1/18.2
R510	7030005720	S.RES ERJ2GEJ 563 X (56 k)	B	81.7/16.6
R511	7030005090	S.RES ERJ2GEJ 104 X (100 k)	B	78.3/16.6
R512	7030005530	S.RES ERJ2GEJ 100 X (10)	B	87.6/16.2
R513	7030005050	S.RES ERJ2GEJ 103 X (10 k)	B	85.2/41.1
R514	7030005060	S.RES ERJ2GEJ 333 X (33 k)	B	87.5/38.8
R515	7030005080	S.RES ERJ2GEJ 823 X (82 k)	B	81.8/34
R516	7030005090	S.RES ERJ2GEJ 104 X (100 k)	B	79.4/32.4
R521	7030005050	S.RES ERJ2GEJ 103 X (10 k)	B	68.3/24.8
R522	7030005090	S.RES ERJ2GEJ 104 X (100 k)	B	53.6/18.8
R523	7030005090	S.RES ERJ2GEJ 104 X (100 k)	B	54.6/18.8
R524	7030005090	S.RES ERJ2GEJ 104 X (100 k)	B	55.6/18.8
R525	7030005090	S.RES ERJ2GEJ 104 X (100 k)	B	56.6/18.8
R526	7030005090	S.RES ERJ2GEJ 104 X (100 k)	B	65.1/23
R527	7030005090	S.RES ERJ2GEJ 104 X (100 k)	B	63.6/23.5
R528	7030005090	S.RES ERJ2GEJ 104 X (100 k)	B	63.6/24.4
R529	7030005090	S.RES ERJ2GEJ 104 X (100 k)	B	65/24.7
R530	7030009280	S.RES ERJ2GEJ 391 X	B	71.6/14.4
R531	7030005000	S.RES ERJ2GEJ 471 X (470)	B	82.7/33
R532	7030005090	S.RES ERJ2GEJ 104 X (100 k)	B	65.2/32.2
R533	7030007250	S.RES ERJ2GEJ 220 X (22)	B	63.2/27.8
	7030010040	S.RES ERJ2GEJ-JPW	B	Except [EUR] [F3161DT/DS]
R534	7030007250	S.RES ERJ2GEJ 220 X (22)	B	64/29.1
	7030010040	S.RES ERJ2GEJ-JPW	B	Except [EUR] [F3161DT/DS]
R535	7030004970	S.RES ERJ2GEJ 470 X (47)	B	69.7/3.4
R536	7030004970	S.RES ERJ2GEJ 470 X (47)	B	69.7/5.4
R537	7030005120	S.RES ERJ2GEJ 102 X (1 k)	B	69.7/4.4
R538	7030005120	S.RES ERJ2GEJ 102 X (1 k)	B	72/3.1
R539	7030005050	S.RES ERJ2GEJ 103 X (10 k)	B	69.7/2.4
R540	7030007340	S.RES ERJ2GEJ 153 X (15 k)	B	80.3/20.2
R541	7030005090	S.RES ERJ2GEJ 104 X (100 k)	B	79.4/20.2
R542	7030005220	S.RES ERJ2GEJ 223 X (22 k)	B	81.7/28.3
R543	7030007340	S.RES ERJ2GEJ 153 X (15 k)	B	82.6/27.1
R544	7030004980	S.RES ERJ2GEJ 101 X (100)	B	82.6/29.9
R546	7030009280	S.RES ERJ2GEJ 391 X	B	[F3161T] only 71.6/15.3
R547	7030009280	S.RES ERJ2GEJ 391 X	B	[F3161T] only 71.6/16.2
R548	7030005230	S.RES ERJ2GEJ 334 X (330 k)	B	74.4/8.5
R552	7030005090	S.RES ERJ2GEJ 104 X (100 k)	B	79.8/30.4
R553	7030005090	S.RES ERJ2GEJ 104 X (100 k)	B	[F3161S] only 72.9/41.7
R554	7030005090	S.RES ERJ2GEJ 104 X (100 k)	B	[F3161T] only 79.4/41.3
R555	7030005050	S.RES ERJ2GEJ 103 X (10 k)	B	74.4/9.4
R557	7030005530	S.RES ERJ2GEJ 100 X (10)	B	87.6/35.7
	7520000270	S.POS PRG21BC4R7MM1RA	B	Except [EUR] [F3161DT/DS]
R558	7030005040	S.RES ERJ2GEJ 472 X (4.7 k)	B	87.6/35.7
R559	7030005040	S.RES ERJ2GEJ 472 X (4.7 k)	B	73.9/18.4
R560	7030005040	S.RES ERJ2GEJ 472 X (4.7 k)	B	77.4/16.6
R561	7030005040	S.RES ERJ2GEJ 472 X (4.7 k)	B	77.5/18.4
R561	7030005000	S.RES ERJ2GEJ 471 X (470)	B	82.7/22.7
R562	7030005000	S.RES ERJ2GEJ 471 X (470)	B	83.4/20.3
R563	7030005050	S.RES ERJ2GEJ 103 X (10 k)	B	80.4/16.6
R564	7030005050	S.RES ERJ2GEJ 103 X (10 k)	B	79.5/16.6
R566	7030010040	S.RES ERJ2GEJ-JPW	B	77.6/20.2
R567	7030005090	S.RES ERJ2GEJ 104 X (100 k)	B	81/30.4
R568	7030005090	S.RES ERJ2GEJ 104 X (100 k)	B	69.8/42.1
R569	7030005090	S.RES ERJ2GEJ 104 X (100 k)	B	70.7/42.1
R570	7030005090	S.RES ERJ2GEJ 104 X (100 k)	B	71.6/42.1
R571	7030005090	S.RES ERJ2GEJ 104 X (100 k)	B	57.1/7.4
C501	4550006760	S.TAN TEESVB21A336M8R	B	93.4/37.3
C502	4550006760	S.TAN TEESVB21A336M8R	B	96.7/37.3
C506	4550006250	S.TAN TEESVA 1A 106M8R	B	75.8/31.1
C507	4550006250	S.TAN TEESVA 1A 106M8R	B	70.5/29
C508	4550006250	S.TAN TEESVA 1A 106M8R	B	70.5/31.1
C509	4030017460	S.CER ECJ0EB1E102K	B	75.6/12.5
C510	4030016930	S.CER ECJ0EB1A104K	B	73.1/20

[FRONT-A UNIT] (for F3160 series)

REF NO.	PARTS NO.	DESCRIPTION	M.	H/V LOCATION
C511	4030017460	S.CER ECJ0EB1E102K	B	75.7/18.4
C514	4550006250	S.TAN TEESVA 1A 106M8R	B	78.5/5.4
C515	4030016930	S.CER ECJ0EB1A104K	B	80.9/18.2
C517	4030016930	S.CER ECJ0EB1A104K	B	80/18.2
C518	4030017460	S.CER ECJ0EB1E102K	B	71.9/26.7
C519	4030016950	S.CER ECJ0EB1A473K	B	87.6/14.6
C520	4030017460	S.CER ECJ0EB1E102K	B	87/41.1
C522	4030016930	S.CER ECJ0EB1A104K	B	85.2/39.9
C523	4030016930	S.CER ECJ0EB1A104K	B	80/34
C525	4030016930	S.CER ECJ0EB1A104K	B	80.9/34
C526	4030017460	S.CER ECJ0EB1E102K	B	70.9/26.7
C527	4030017460	S.CER ECJ0EB1E102K	B	86.1/41.1
C528	4030016930	S.CER ECJ0EB1A104K	B	80.3/41.3
C529	4030016930	S.CER ECJ0EB1A104K	B	58/29.5
C530	4030017460	S.CER ECJ0EB1E102K	B	81.2/41.3
C531	4030017460	S.CER ECJ0EB1E102K	B	56.4/29.5
C532	4550007090	S.TAN TEESVA 1A 226M8R	B	67.4/39.9
C534	4030016930	S.CER ECJ0EB1A104K	B	85.8/38.2
C535	4030016790	S.CER ECJ0EB1C103K	B	64.9/38.2
C536	4550005980	S.TAN TEESVA 1A 475M8R	B	67/31.5
C537	4030016930	S.CER ECJ0EB1A104K	B	55/37.7
C538	4550000460	S.TAN TEESVA 1C 105M8R	B	54.6/31.9
C539	4030016930	S.CER ECJ0EB1A104K	B	82.6/28.3
C540	4030018140	S.CER ECJ0EB1H391K	B	81.2/20.2
C541	4030016930	S.CER ECJ0EB1A104K	B	74.4/7.6
C542	4030017440	S.CER ECJ0EC1H221J	B	79.8/29.4
C543	4550006250	S.TAN TEESVA 1A 106M8R	B	75.8/29
C544	4030017460	S.CER ECJ0EB1E102K	B	82.6/26.2
C551	4030017420	S.CER ECJ0EC1H470J	T	87.9/24.4
C552	4030017420	S.CER ECJ0EC1H470J	T	87.9/23.5
C554	4030017420	S.CER ECJ0EC1H470J	T	87.9/21.7
C556	4030017420	S.CER ECJ0EC1H470J	T	87.9/25.3
C558	4030017420	S.CER ECJ0EC1H470J	T	87.8/28
C559	4030016790	S.CER ECJ0EB1C103K	T	87.8/27.1
C560	4030017770	S.CER ECJ0EB1E332K	B	78.5/20.2
C561	4030016930	S.CER ECJ0EB1A104K	B	82.4/31.1
C562	4030017460	S.CER ECJ0EB1E102K	B	69.1/19.5
C563	4030017420	S.CER ECJ0EC1H470J	B	[F3161DT/DS] only 64.3/32.2
J501	6510025240	S.CNR IMSA-9631S-20Y912	B	63.5/11.4
J502	6510025250	S.CNR IMSA-9631S-08Y912	B	58.8/35.5
J503	6510025260	S.CNR IMSA-9631S-10Y912	B	89.8/24.4
DS501	5040002961	S.LED SML-A12MT T86J	T	82.9/33.6
DS502	5040002961	S.LED SML-A12MT T86J	T	82.9/23.1
DS503	5040002961	S.LED SML-A12MT T86J	T	82.9/12.6
DS504	5040002420	S.LED SML-310MT T86	T	38.1/12.9
DS505	5040002420	S.LED SML-310MT T86	T	38.1/30.9
DS506	5040002420	S.LED SML-310MT T86	T	[F3161T] only 29.2/14.9
DS507	5040002420	S.LED SML-310MT T86	T	[F3161T] only 29.2/28.9
DS508	5040002420	S.LED SML-310MT T86	T	[F3161T] only 11.7/14.9
DS509	5040002420	S.LED SML-310MT T86	T	[F3161T] only 11.7/28.9
DS510	5030003140	LCD M7-0626TIZ		
MC501	7700002760	MIC EM6027P-46C33-G-01		
W501	9028930010	WIR 23/04/020/W02/W02		
W502	9014506004	WIR 23/00/025/W02/W02		

M.=Mounted side (T: Mounted on the Top side, B: Mounted on the Bottom side)
S.=Surface mount

[MAIN-A UNIT] (for F3160 series)

Table with 5 columns: REF NO., PARTS NO., DESCRIPTION, M., H/V LOCATION. Lists parts for F3160 series including ERJ2GEJ and ERJ2GEE components.

[MAIN-A UNIT] (for F3160 series)

Table with 5 columns: REF NO., PARTS NO., DESCRIPTION, M., H/V LOCATION. Lists parts for F3160 series including ECJ0EC and ECJ0EB components.

M.=Mounted side (T: Mounted on the Top side, B: Mounted on the Bottom side) S.=Surface mount

[MAIN-A UNIT] (for F3160 series)

REF NO.	PARTS NO.	DESCRIPTION	M.	H/V LOCATION
EP1	6910015370	S.BEA ACZ1005Y-102-T	B	53.5/22.5
EP3	6910015370	S.BEA ACZ1005Y-102-T	B	45.5/36.8
EP4	6910015600	S.BEA ACZ1005Y-241 (240)	B	56.4/39.6
EP5	6910015370	S.BEA ACZ1005Y-102-T	B	62.6/21.7
EP7	0880002600	UBD EX-2887 [F3062S EUR-01], [F3160DT/DS]		

[RF UNIT]

REF NO.	PARTS NO.	DESCRIPTION	M.	H/V LOCATION
IC601	1110002750	S.IC TA75S01F (TE85R) Except [FRG-01]	T	24.4/23.1
	1110002751	S.IC TA75S01F (TE85R,F) [FRG-01]	T	24.4/23.1
Q601	1560001230	S.FET RD07MVS1 [F3061T], [F3063T], [F3061S], [F3063S]	B	8/6.5
	1560001231	S.FET RD07MVS1-T112 [F3062T], [F3062S EUR-01], [FRG-01]	B	8/6.5
Q602	1560001241	S.FET RD01MUS1-T113	B	3.5/13.2
Q603	1530003420	S.TR 2SC5110-O (TE85R) [F3061T], [F3063T], [F3061S], [F3063S]	B	8/18.1
	1530003421	S.TR 2SC5110-O (TE85R,F) [F3062T], [F3062S EUR-01], [FRG-01]	B	8/18.1
Q604	1590002160	S.TR XP6401-(TX)	T	7.7/15.3
Q605	1530002060	S.TR 2SC4081 T106 R	T	8/17.9
Q606	1590003290	S.TR UNR9213J-(TX)	T	21/20.5
D601	1750000580	S.DIO 1SV307 (TPH3) [F3061T], [F3063T], [F3061S], [F3063S]	T	22.4/10
	1750000581	S.DIO 1SV307 (TPH3,F) [F3062T], [F3062S EUR-01], [FRG-01]	T	22.4/10
D603	1750000580	S.DIO 1SV307 (TPH3) [F3061T], [F3063T], [F3061S], [F3063S]	B	17.8/13.2
	1750000581	S.DIO 1SV307 (TPH3,F) [F3062T], [F3062S EUR-01], [FRG-01]	B	17.8/13.2
D604	1790001670	S.DIO RB706F-40T106	T	17.4/6.1
D605	1790001670	S.DIO RB706F-40T106	B	28.4/21.7
D606	1790001250	S.DIO MA2S111-(TX)	T	29.8/21.7
D607	1730002430	S.ZEN MA8150-M (TX) [F3062T], [F3060S]	T	17.2/21.4
L601	6200008580	S.COL 0.30-1.4-6TL 32N Except [FRG-01]	B	30.8/9.2
	6200012780	S.COL 0.30-1.4-6TL 27.2N [FRG-01]	B	30.8/9.2
L602	6200008280	S.COL 0.30-1.7-7TL 50N Except [FRG-01]	B	30.2/12.4
L602	6200012470	S.COL 0.30-1.7-7TL 45.3N [FRG-01]	B	30.2/12.4
L603	6200008170	S.COL 0.35-1.6-8TL 54N Except [FRG-01]	B	27.3/15.7
	6200012910	S.COL 0.35-1.6-8TL 45.5N [FRG-01]	B	27.3/15.7
L604	6200008280	S.COL 0.30-1.7-7TL 50N Except [FRG-01]	B	20.1/13.1
	6200012470	S.COL 0.30-1.7-7TL 45.3N [FRG-01]	B	20.1/13.1
L605	6200002861	S.COL NLV25T-4R7J	T	25.2/11.1
L606	6200008580	S.COL 0.30-1.4-6TL 32N Except [FRG-01]	B	20.5/4.4
	6200012780	S.COL 0.30-1.4-6TL 27.2N [FRG-01]	B	20.5/4.4
L607	6200008490	S.COL 0.30-0.9-3TR 7.5N Except [FRG-01]	B	16/4.1
	6200012390	S.COL 0.30-0.92-3TR 5.8N [FRG-01]	B	16/4.1
L608	6200009710	S.COL 0.30-0.9-4TL 10.5N Except [FRG-01]	B	12.6/5.6
	6200012400	S.COL 0.30-0.91-4TL 8.6N [FRG-01]	B	12.6/5.6
L609	6200008330	S.COL 0.45-1.4-4TL 15N Except [FRG-01]	B	9.2/11.8
	6200012960	S.COL 0.45-1.4-4TL 12.1N [FRG-01]	B	9.2/11.8
L610	6200005711	S.COL ELJRE 27NGFA	B	6.7/13.8
L611	6200003590	S.COL EXCCL3225U1	B	14.6/17.4
L612	6200005731	S.COL ELJRE 39NGFA	B	4.6/18.6
L613	6200006190	S.COL BLM21PG300SN1D	T	13.1/20.2
R601	7030003680	S.RES ERJ3GEYJ 104 V (100 k)	T	29/8.3
R603	7030009140	S.RES ERJ2GEJ 272 X (2.7 k)	B	18/3.3
R604	7030005040	S.RES ERJ2GEJ 472 X (4.7 k)	T	17.7/9
R605	7030005040	S.RES ERJ2GEJ 472 X (4.7 k)	T	17.7/10
R606	7030005050	S.RES ERJ2GEJ 103 X (10 k)	T	27.6/20.4
R607	7030005090	S.RES ERJ2GEJ 104 X (100 k)	T	19.4/20.9
R608	7030005110	S.RES ERJ2GEJ 224 X (220 k)	T	26.6/22
R609	7030005530	S.RES ERJ2GEJ 100 X (10)	B	24.1/24.7
R610	7030007290	S.RES ERJ2GEJ 222 X (2.2 k)	T	28.6/22
R611	7030004990	S.RES ERJ2GEJ 221 X (220)	T	29.4/20
R613	7030005090	S.RES ERJ2GEJ 104 X (100 k)	B	4.2/7.4
R614	7030005040	S.RES ERJ2GEJ 472 X (4.7 k)	B	2.4/8.6
R615	7030007250	S.RES ERJ2GEJ 220 X (22)	B	4/8.6
R616	7030005060	S.RES ERJ2GEJ 333 X (33 k)	B	3.4/17.4
R617	7030005040	S.RES ERJ2GEJ 472 X (4.7 k)	B	2.4/18.4
R618	7030004980	S.RES ERJ2GEJ 101 X (100)	B	3.8/16.2
R619	7030004980	S.RES ERJ2GEJ 101 X (100)	B	6/17.7
R620	7030007290	S.RES ERJ2GEJ 222 X (2.2 k)	B	7.7/21.2
R621	7030007290	S.RES ERJ2GEJ 222 X (2.2 k)	B	6.7/20
R622	7030005530	S.RES ERJ2GEJ 100 X (10)	T	6.8/21.4
R623	7030007330	S.RES ERJ1WRSJR15U (0.15)	T	16/16.8
R624	7030005120	S.RES ERJ2GEJ 102 X (1 k)	T	12.9/14.4
R625	7030005050	S.RES ERJ2GEJ 103 X (10 k)	T	6/18.1
R626	7030005120	S.RES ERJ2GEJ 102 X (1 k)	T	7.7/20.2
R627	7030005060	S.RES ERJ2GEJ 333 X (33 k)	T	6.7/20.2
R628	7030003370	S.RES ERJ3GEYJ 271 V (270)	T	26.7/17
R629	7030003370	S.RES ERJ3GEYJ 271 V (270)	T	25.4/17
R631	7030008300	S.RES ERJ2GEJ 184 X (180 k)	T	21.7/18.7
R632	7030009140	S.RES ERJ2GEJ 272 X (2.7 k)	B	28.7/19.2
R633	7030005040	S.RES ERJ2GEJ 472 X (4.7 k) [F3061T], [F3063T]	B	26.5/20.8
	7030007340	S.RES ERJ2GEJ 153 X (15 k) [F3062T], [F3060S]	B	26.5/20.8
C601	4030006990	S.CER C1608 CH 1H 080D-T	B	30.6/6.4
C602	4030011770	S.CER C1608 CH 1H 060B-T	B	33.1/10.5
C604	4030009650	S.CER C1608 CH 1H 240J-T	B	28.5/7.7
C605	4030009920	S.CER C1608 CH 1H 050B-T	B	32.3/13.1

M.=Mounted side (T: Mounted on the Top side, B: Mounted on the Bottom side)
S.=Surface mount

[RF UNIT]

REF NO.	PARTS NO.	DESCRIPTION	M.	H/V LOCATION
C606	4030007060	S.CER C1608 CH 1H 270J-T	B	28.1/11.7
C608	4030009540	S.CER C1608 CH 1H 1R5B-T	B	27.7/17.8
C609	4030007020	S.CER C1608 CH 1H 120J-T	B	25.5/11.7
C610	4030017460	S.CER ECJ0EB1E102K	B	24.1/12.1
C611	4030007020	S.CER C1608 CH 1H 120J-T	B	23.4/10.3
C612	4030017650	S.CER ECJ0EC1H270J	B	21.1/15.5
C613	4030017460	S.CER ECJ0EB1E102K	T	25.8/13.3
C614	4030017460	S.CER ECJ0EB1E102K	T	25.3/19.2
C615	4030017460	S.CER ECJ0EB1E102K	T	21.7/8
C616	4030007040	S.CER C1608 CH 1H 180J-T	B	20.9/8
C617	4030007040	S.CER C1608 CH 1H 180J-T	B	19.6/8
C618	4030017530	S.CER ECJ0EC1H0R5B	T	17.4/3.8
C619	4030017460	S.CER ECJ0EB1E102K	T	17.7/8
C620	4030017460	S.CER ECJ0EB1E102K	B	19.3/6.3
C622	4030011770	S.CER C1608 CH 1H 060B-T	B	18.3/8
C623	4030007100	S.CER C1608 CH 1H 560J-T	B	17.9/5.4
C624	4030007110	S.CER C1608 CH 1H 680J-T	B	14.5/6.5
C626	4030017460	S.CER ECJ0EB1E102K	T	28.2/17.5
C627	4030016790	S.CER ECJ0EB1C103K	T	21.8/22.3
C628	4030016930	S.CER ECJ0EB1C103K	T	27.6/22
		S.CER ECJ0EB1A104K	T	
		[F3061T], [F3063T], [F3061S], [F3063S]	T	27.6/22
	4030016940	S.CER ECJ0EB1A393K	T	
		[F3062T], [F3062S EUR-01], [FRG-01]	T	27.6/22
C629	4030017460	S.CER ECJ0EB1E102K	B	25.8/18.8
C630	4030016930	S.CER ECJ0EB1A104K	T	24.5/25.3
C631	4030017460	S.CER ECJ0EB1E102K	T	28.6/18.7
C632	4030017460	S.CER ECJ0EB1E102K	B	21/20.2
C633	4030017460	S.CER ECJ0EB1E102K	B	13.7/15.4
C634	4030017460	S.CER ECJ0EB1E102K	B	2.2/7.4
C635	4030017730	S.CER ECJ0EB1E471K	B	3.2/7.4
C637	4030017460	S.CER ECJ0EB1E102K	T	3.1/9.3
C638	4030017430	S.CER ECJ0EC1H101J	B	4.7/9.8
C639	4030017490	S.CER C1608 JB 1A 105K-T	B	13.8/14.2
C640	4030017460	S.CER ECJ0EB1E102K	B	8.1/14.7
C642	4030016790	S.CER ECJ0EB1C103K	B	2.2/16.2
C643	4030017460	S.CER ECJ0EB1E102K	B	2.2/17.2
C644	4030017420	S.CER ECJ0EC1H470J	T	2/18.8
C645	4030017460	S.CER ECJ0EB1E102K	T	4.2/18.8
C646	4030017430	S.CER ECJ0EC1H101J	B	5/16.5
C647	4030017420	S.CER ECJ0EC1H470J	T	5.6/21.5
C648	4030017460	S.CER ECJ0EB1E102K	B	5.7/21.5
C649	4030017460	S.CER ECJ0EB1E102K	T	10.1/22.8
C650	4030017460	S.CER ECJ0EB1E102K	B	6/18.7
C651	4030017650	S.CER ECJ0EC1H270J	B	8.3/20
C653	4030017460	S.CER ECJ0EB1E102K	T	17.2/14.2
C654	4030017460	S.CER ECJ0EB1E102K	T	6/17.1
C655	4030017460	S.CER ECJ0EB1E102K	T	8.7/20.2
C656	4030016930	S.CER ECJ0EB1A104K	T	16.5/19.4
C657	4030017460	S.CER ECJ0EB1E102K	T	15.5/19.4
C658	4030017420	S.CER ECJ0EC1H470J	T	14.5/19.4
C659	4030017420	S.CER ECJ0EC1H470J	T	14.7/21.2
C660	4030017460	S.CER ECJ0EB1E102K	T	13.2/23.8
C661	4030016930	S.CER ECJ0EB1A104K	T	12.2/23.8
C662	4030017460	S.CER ECJ0EB1E102K	B	6.8/11.2
C663	4030009920	S.CER C1608 CH 1H 050B-T	B	34.3/10.5
C664	4030011770	S.CER C1608 CH 1H 060B-T	B	15.7/6.5
C665	4030017530	S.CER ECJ0EC1H0R5B	B	29.8/20.1
C666	4030017460	S.CER ECJ0EB1E102K	B	26.5/22.4
C667	4030018910	S.CER C1608 JB 0J 475K-T	B	
		[F3062T], [F3062S EUR-01], [FRG-01] only	B	23.5/22.3
J601	6910017940	CNR IMSA-9230B-1-05Z118-PT1		
J602	6910017940	CNR IMSA-9230B-1-05Z118-PT1		
F601	5210000970	S.FUS ERBSE3R00U	T	13.9/22.4
EP602	6910012350	S.BEA MMZ1608Y 102BT	B	7.8/15.8

[JACK UNIT]

REF NO.	PARTS NO.	DESCRIPTION	M.	H/V LOCATION
D801	1790001810	S.VSR AVR-M1005C080MTABB	B	13.7/1.7
D802	1790001810	S.VSR AVR-M1005C080MTABB	B	14.7/3.8
D803	1790001810	S.VSR AVR-M1005C080MTABB	B	13.8/3.8
D804	1790001810	S.VSR AVR-M1005C080MTABB	B	14.1/2.6
D805	1790001810	S.VSR AVR-M1005C080MTABB	B	13.5/0.8
J801	6510025140	S.CNR 10FLT-SM1-TB Except [FRG-01]	B	5/2.6
	6510025141	S.CNR 10FLT-SM2-TB (LF) [FRG-01]	B	5/2.6
EP801	6910012350	S.BEA MMZ1608Y 102BT	B	10/3.7
EP802	6910012350	S.BEA MMZ1608Y 102BT	B	10/2.2
EP803	6910012350	S.BEA MMZ1608Y 102BT	B	10/9

[VR UNIT] (for other than [FRG-01])

REF NO.	PARTS NO.	DESCRIPTION	M.	H/V LOCATION
Q701	1590001400	S.TR XP1214 (TX)	T	32.2/6.2
R701	7410001140	S.ARY EXB28V104JX	T	11.4/1.8
R702	7030007280	S.RES ERJ2GEJ 331 X (330)	T	31.7/8.6
R703	7030005030	S.RES ERJ2GEJ 152 X (1.5 k)	T	32.7/8.6
R704	7210003061	VAR TP76N00N-15F-A103-2251A		
R705	7030005090	S.RES ERJ2GEJ 104 X (100 k)	T	13.2/2.8
C701	4030017420	S.CER ECJ0EC1H470J	T	10.1/5.2
C702	4030017420	S.CER ECJ0EC1H470J	T	11.1/5.2
C703	4030017420	S.CER ECJ0EC1H470J	T	12.1/5.2
C704	4030017420	S.CER ECJ0EC1H470J	T	14.3/3.2
J701	6510024930	S.CNR 20RF-JMCSG1BTF (N) (LF)(SN)	B	11.4/4.1
DS701	5040002670	S.LED CL-165HR/YG	T	33.5/11.1
S701	2250000490	ECR TP70TF5163-15.9F-2775		
S702	2230001060	S.SW EVQ-PUL 02K	T	8/10.4

[VR-A UNIT] (for [FRG-01])

REF NO.	PARTS NO.	DESCRIPTION	M.	H/V LOCATION
Q701	1590001400	S.TR XP1214 (TX)	T	32.2/6.2
R701	7410001140	S.ARY EXB28V104JX	T	11.2/1.8
R702	7030007280	S.RES ERJ2GEJ 331 X (330)	T	31.7/8.6
R703	7030005030	S.RES ERJ2GEJ 152 X (1.5 k)	T	32.7/8.6
R704	7210003061	VAR TP76N00N-15F-A103-2251A		
R705	7030005090	S.RES ERJ2GEJ 104 X (100 k)	T	13.1/2.9
C701	4030017420	S.CER ECJ0EC1H470J	T	10.1/5.2
C702	4030017420	S.CER ECJ0EC1H470J	T	11.1/5.2
C703	4030017420	S.CER ECJ0EC1H470J	T	12.1/5.2
C704	4030017420	S.CER ECJ0EC1H470J	T	14/3.9
J701	6510024930	S.CNR 20RF-JMCSG1BTF (N) (LF)(SN)	B	11.4/4.1
DS701	5040002670	S.LED CL-165HR/YG	T	33.5/11.1
S701	2250000600	ECR TP70N1035E20-15.9F-2893		
S702	2230001060	S.SW EVQ-PUL 02K	T	8/10.4

M.=Mounted side (T: Mounted on the Top side, B: Mounted on the Bottom side)
S.=Surface mount

BOARD LAYOUTS

• For F3060 series

• FRONT UNIT (TOP VIEW)

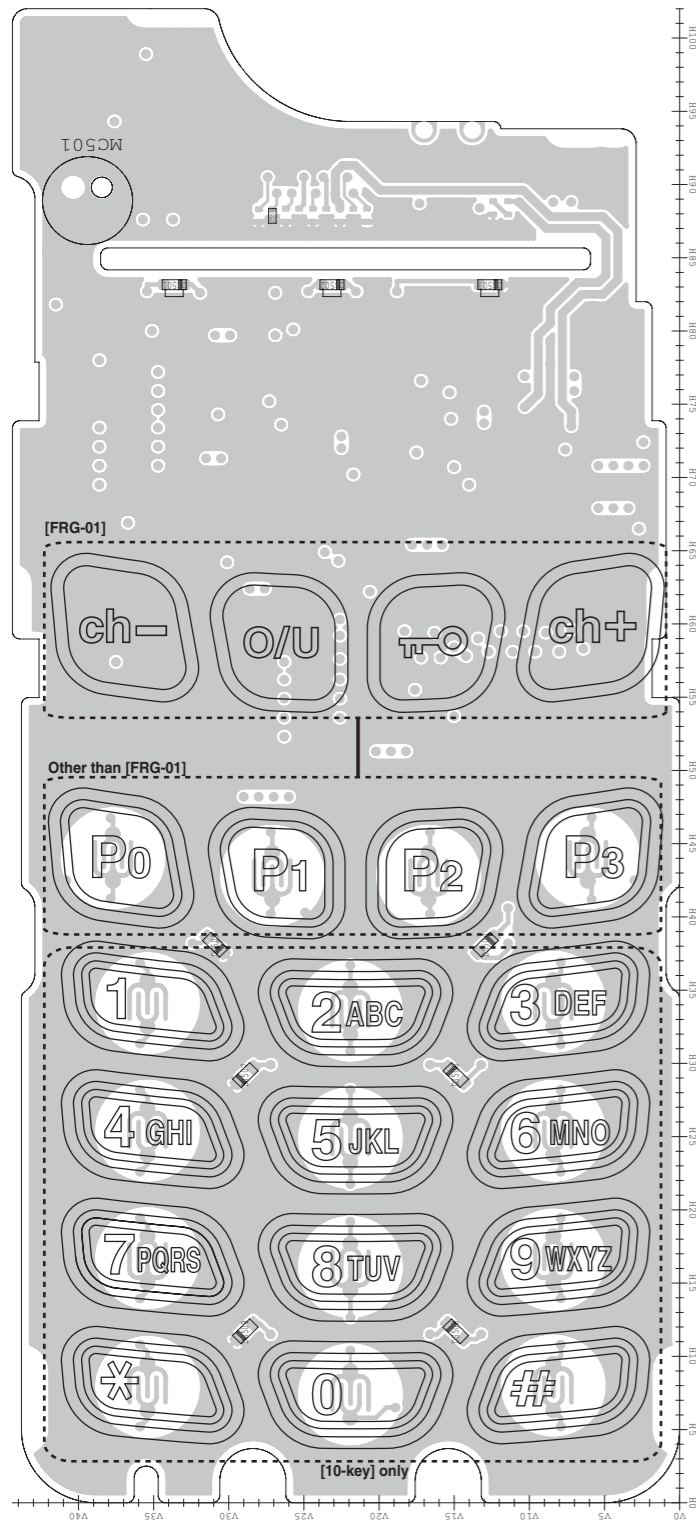

• MAIN UNIT (TOP VIEW)

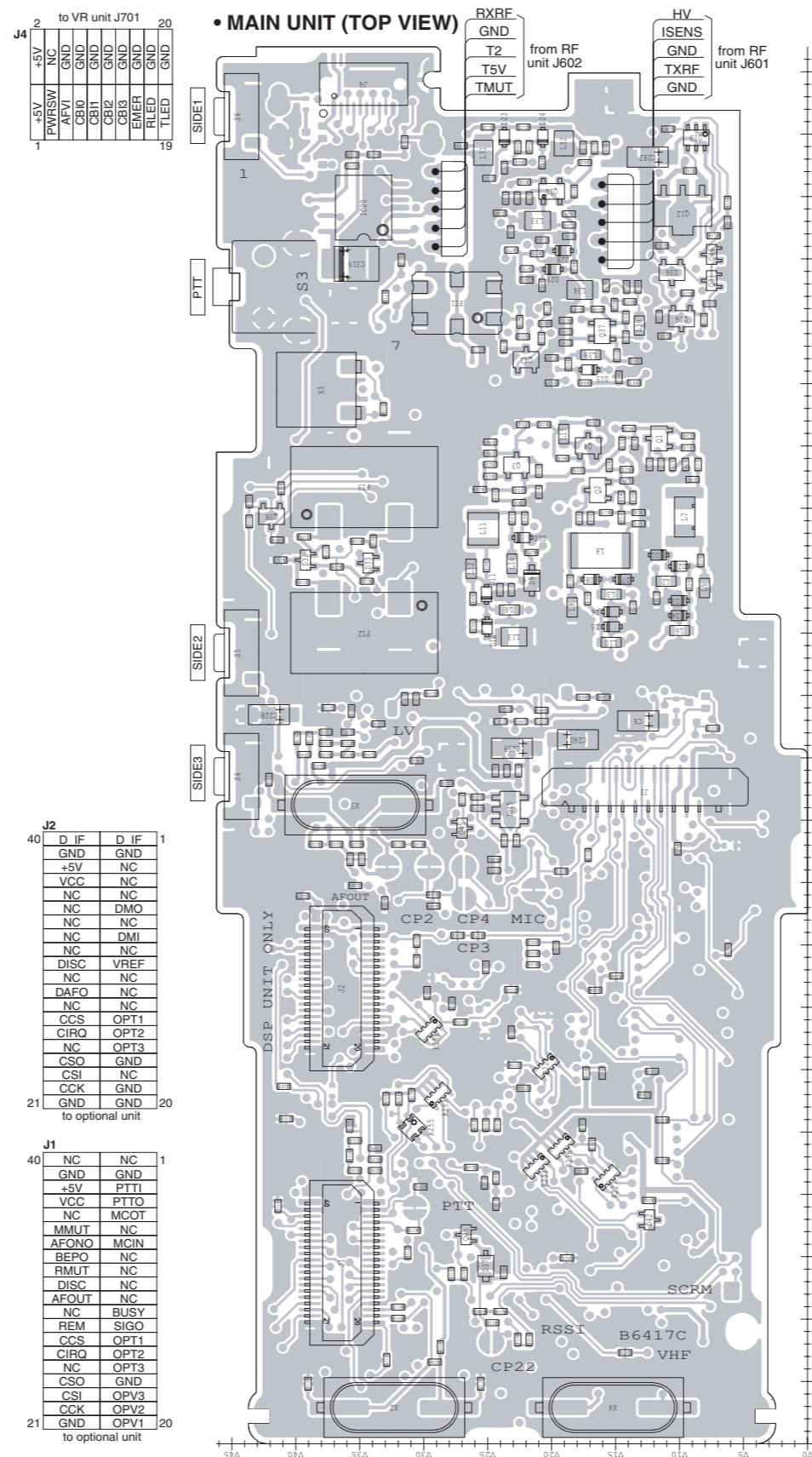

• RF UNIT (TOP VIEW)

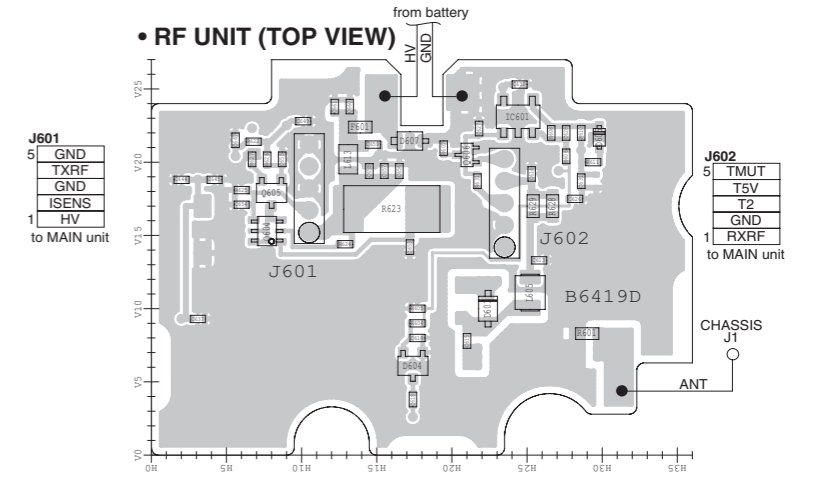

• JACK UNIT (TOP VIEW)

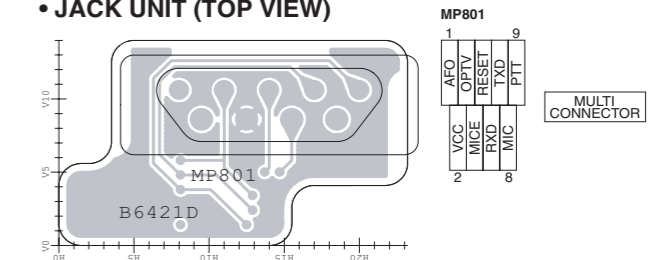

• VR UNIT (TOP VIEW)

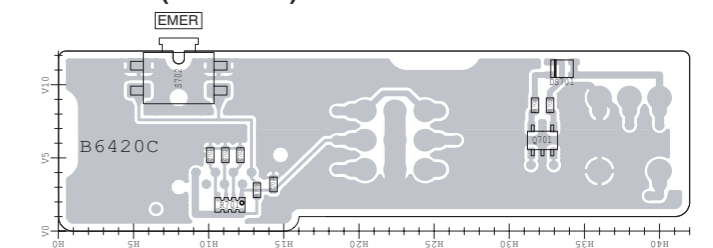

• VR-A UNIT (TOP VIEW) ([FRG-01] only)

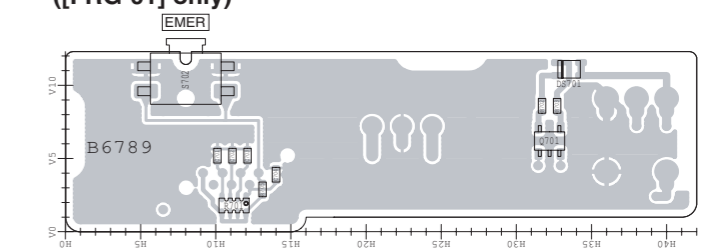

• BC-160 (TOP VIEW)

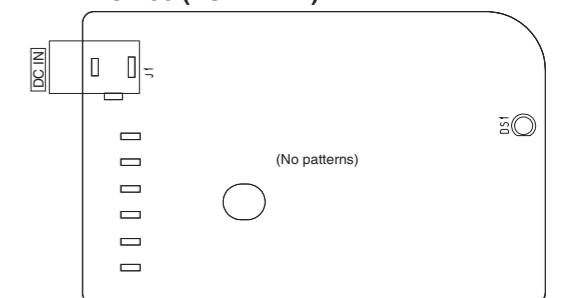

• RF UNIT (BOTTOM VIEW)

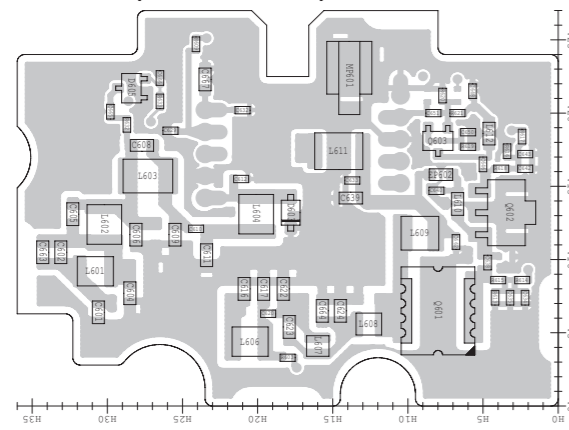

• JACK UNIT (BOTTOM VIEW)

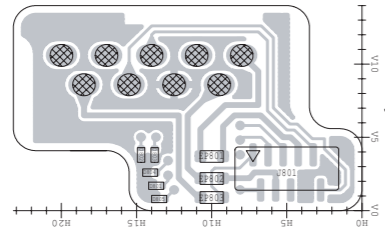

1	EPITT
2	EMIC
3	VCC
4	NC
5	GND
6	EAFO
7	RES
8	NC
9	RES
10	CLI

to FRONT unit J503

• VR UNIT (BOTTOM VIEW)

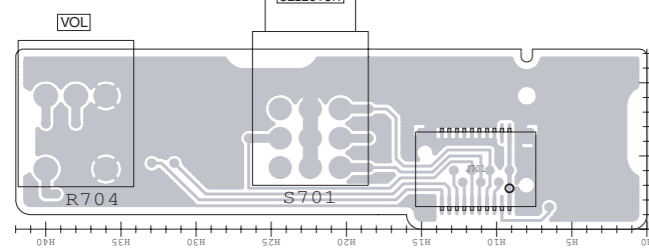

1	+5V
2	NC
3	GND
4	AFRSW
5	AFVI
6	CB0
7	CB1
8	CB2
9	GND
10	GND
11	GND
12	GND
13	CB3
14	EMER
15	FLER
16	TLER
17	TLER
18	GND
19	TLER
20	GND

to MAIN unit J4

• VR-A UNIT (BOTTOM VIEW) ([FRG-01] only)

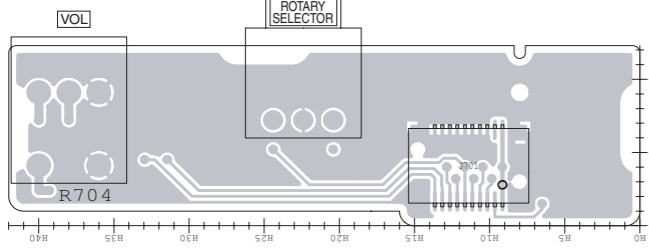

1	+5V
2	NC
3	GND
4	AFRSW
5	AFVI
6	CB0
7	CB1
8	CB2
9	GND
10	GND
11	GND
12	GND
13	CB3
14	EMER
15	FLER
16	TLER
17	TLER
18	GND
19	TLER
20	GND

to MAIN unit J4

• BC-160 (BOTTOM VIEW)

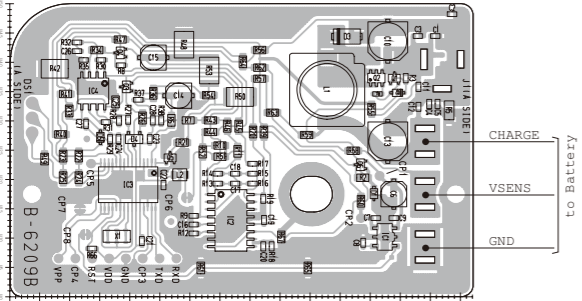

• MAIN UNIT (BOTTOM VIEW)

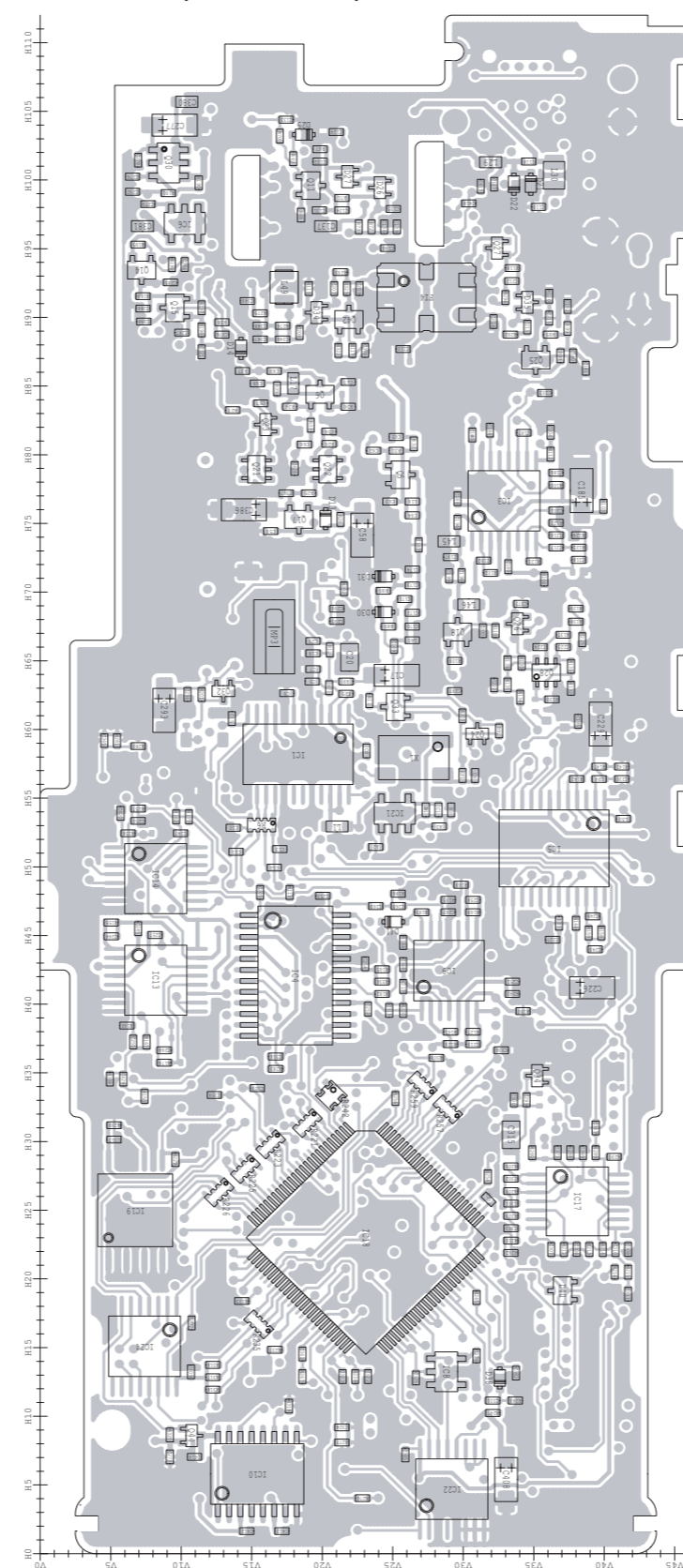

• FRONT UNIT (BOTTOM VIEW)

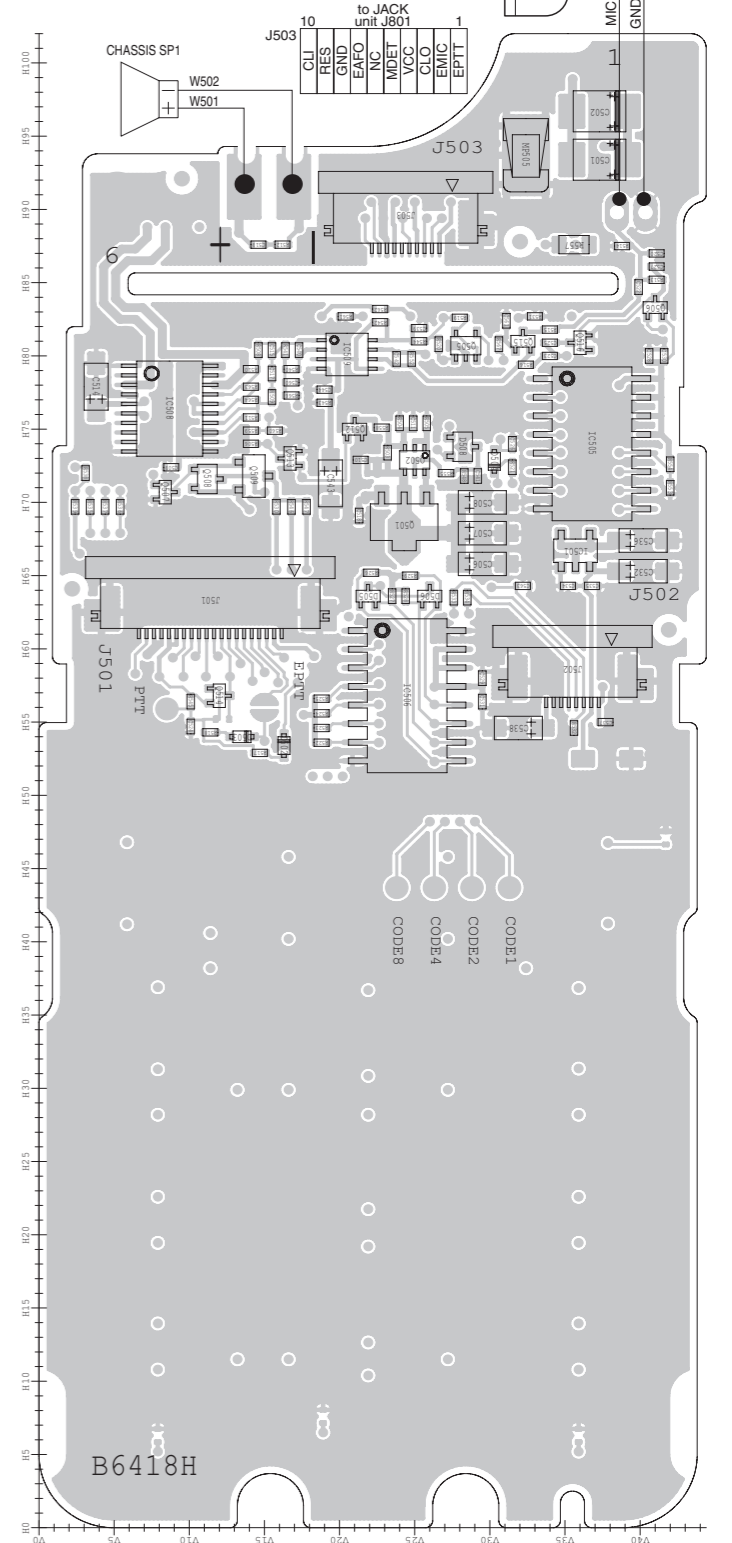

The combination of this side and the bottom side shows the board layout in the same configuration as the actual P.C.Board.

1	GND
2	MDET
3	VCC
4	+5V
5	AS+
6	CLO
7	RES
8	FSC
9	FSDA
10	PITTSW
11	PITI
12	RR
13	CLI
14	AFONO
15	URES
16	EPIT
17	AF
18	MCIN
19	GND
20	GND

to MAIN unit J3

1	AS+
2	AS+
3	SRES
4	TSCL
5	TSCL
6	GND
7	LDL V
8	GND

to LCD

• FRONT-A UNIT (TOP VIEW)

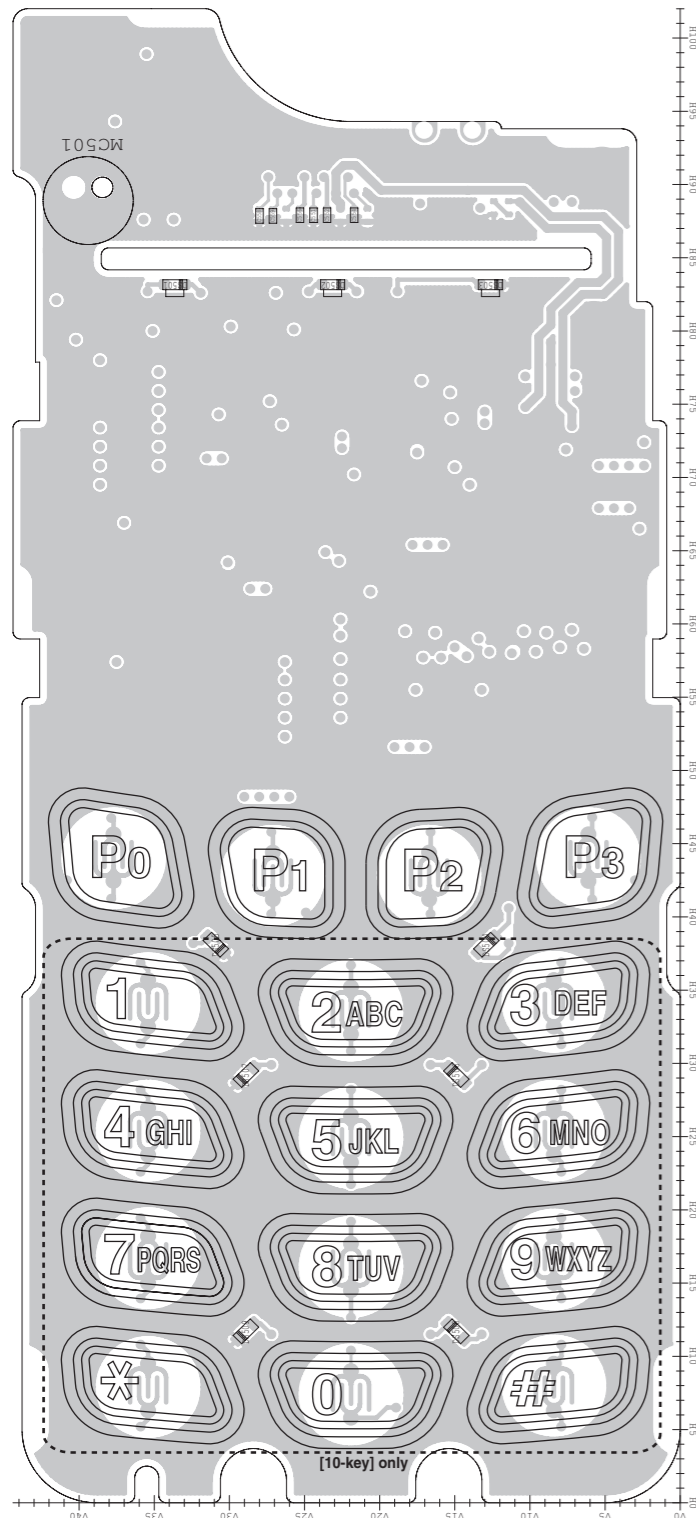

J4 to VR unit J701

2	+5V	NC	20
1	PWRSM	GND	19
	AFVI	GND	
	CB10	GND	
	CB11	GND	
	CB12	GND	
	CB13	GND	
	EMER	GND	
	FILED	GND	

• MAIN-A UNIT (TOP VIEW)

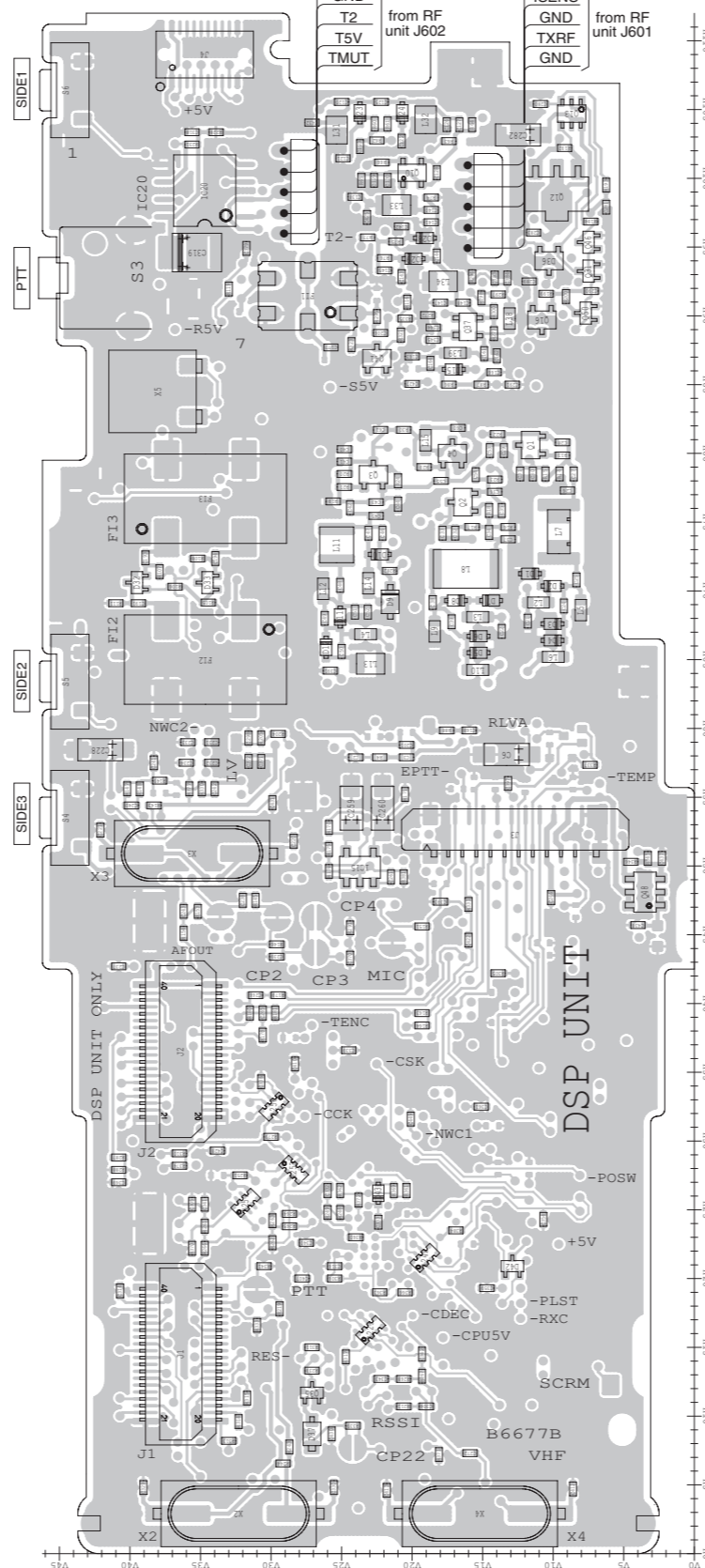

J2

40	D IF	D IF	1
	GND	GND	
	+5V	NC	
	VCC	NC	
	NC	NC	
	NC	DMO	
	NC	NC	
	NC	DMI	
	NC	NC	
	DISC	VREF	
	NC	NC	
	DAFO	NC	
	NC	NC	
	CCS	OPT1	
	CIRQ	OPT2	
	NC	OPT3	
	CSO	GND	
	CSI	NC	
	CCK	GND	
21	GND	GND	20

to optional unit

J1

40	NC	NC	1
	GND	GND	
	+5V	PTTI	
	VCC	PTTO	
	NC	MCOT	
	MMUT	NC	
	AFONO	MCIN	
	BEPO	NC	
	RMUT	NC	
	DISC	NC	
	AFOUT	NC	
	NC	BUSY	
	REM	SIGO	
	CCS	OPT1	
	CIRQ	OPT2	
	NC	OPT3	
	CSO	GND	
	CSI	OPV3	
	CCK	OPV2	
21	GND	OPV1	20

to optional unit

J3 to FRONT unit J501

1	GND	28
	MCIN	
	AF	
	EPIT	
	LRES	
	AFONO	
	CLI	
	KR	
	PTTI	
	PITTSW	
	FSDA	
	FSCL	
	RES	
	CLO	
	+5V	
	VCC	
	VCC	
	MDET	
	GND	

The combination of this side and the bottom side shows the board layout in the same configuration as the actual P.C.Board.

• RF UNIT (TOP VIEW)

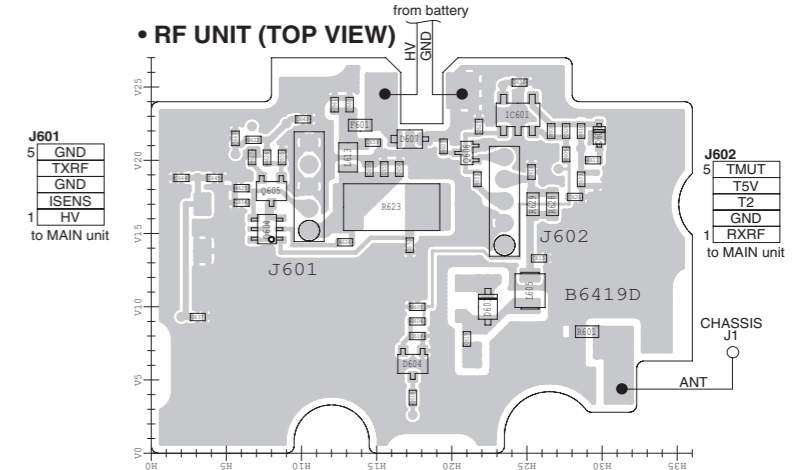

J601 to MAIN unit

5	GND	
	TXRF	
	GND	
	ISENS	
1	HV	

J602 to MAIN unit

5	TMUT	
	T5V	
	T2	
	GND	
1	RXRF	

• JACK UNIT (TOP VIEW)

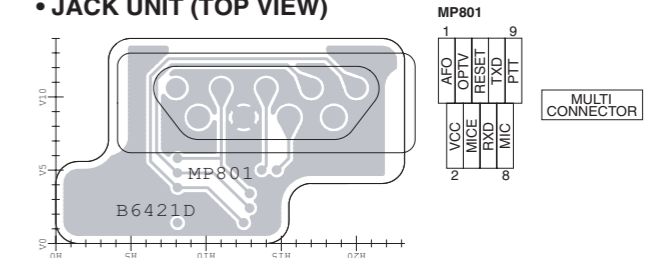

MP801 MULTI CONNECTOR

1	AFQ	9
	OPTV	
	RESET	
	RXD	
	TXD	
	PTT	
2	VCC	8
	MIC	
	RXD	
	MIC	

• VR UNIT (TOP VIEW)

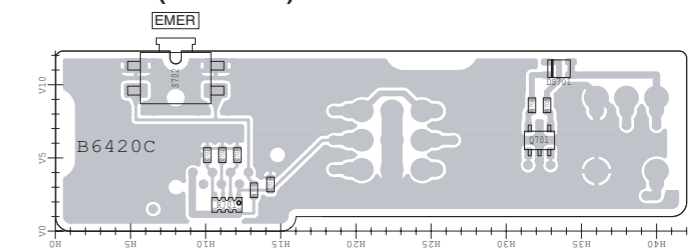

• BC-160 (TOP VIEW)

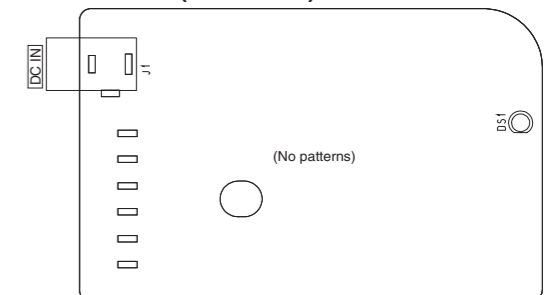

• RF UNIT (BOTTOM VIEW)

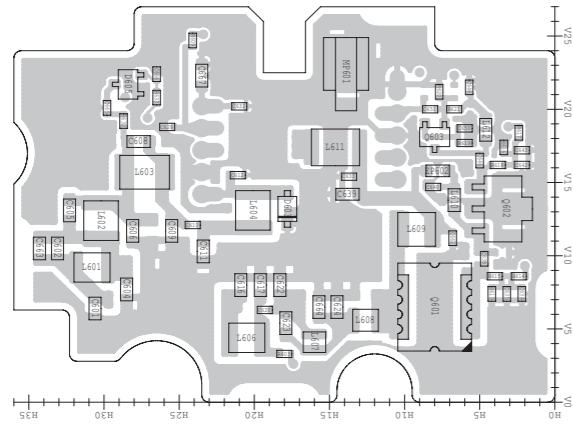

• JACK UNIT (BOTTOM VIEW)

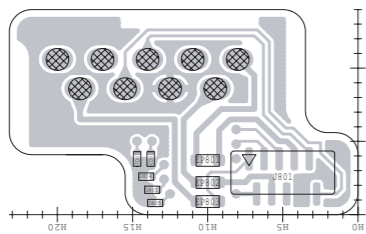

1	EPTT	9
2	EMIC	10
	VCC	
	NC	
	GND	
	RES	
	CLI	

to FRONT unit J503

• VR UNIT (BOTTOM VIEW)

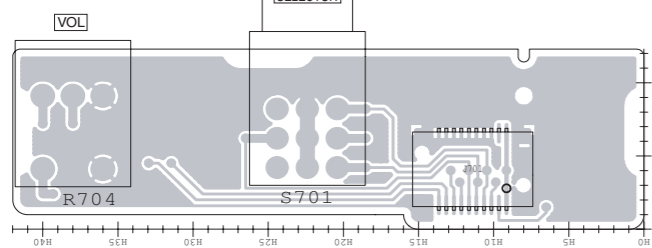

20	GND	2
19	TLCD	1
	EMER	
	CB2	
	CB1	
	CB0	
	AFVI	
	PWRSW	
	NC	
	+5V	

to MAIN unit J4

• BC-160 (BOTTOM VIEW)

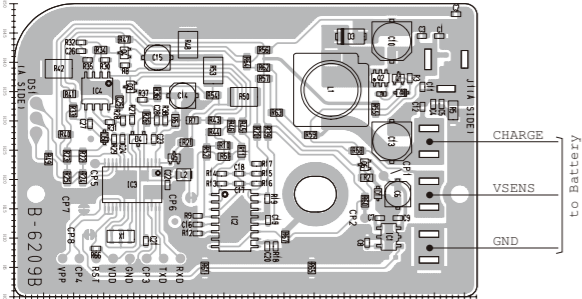

• MAIN-A UNIT (BOTTOM VIEW)

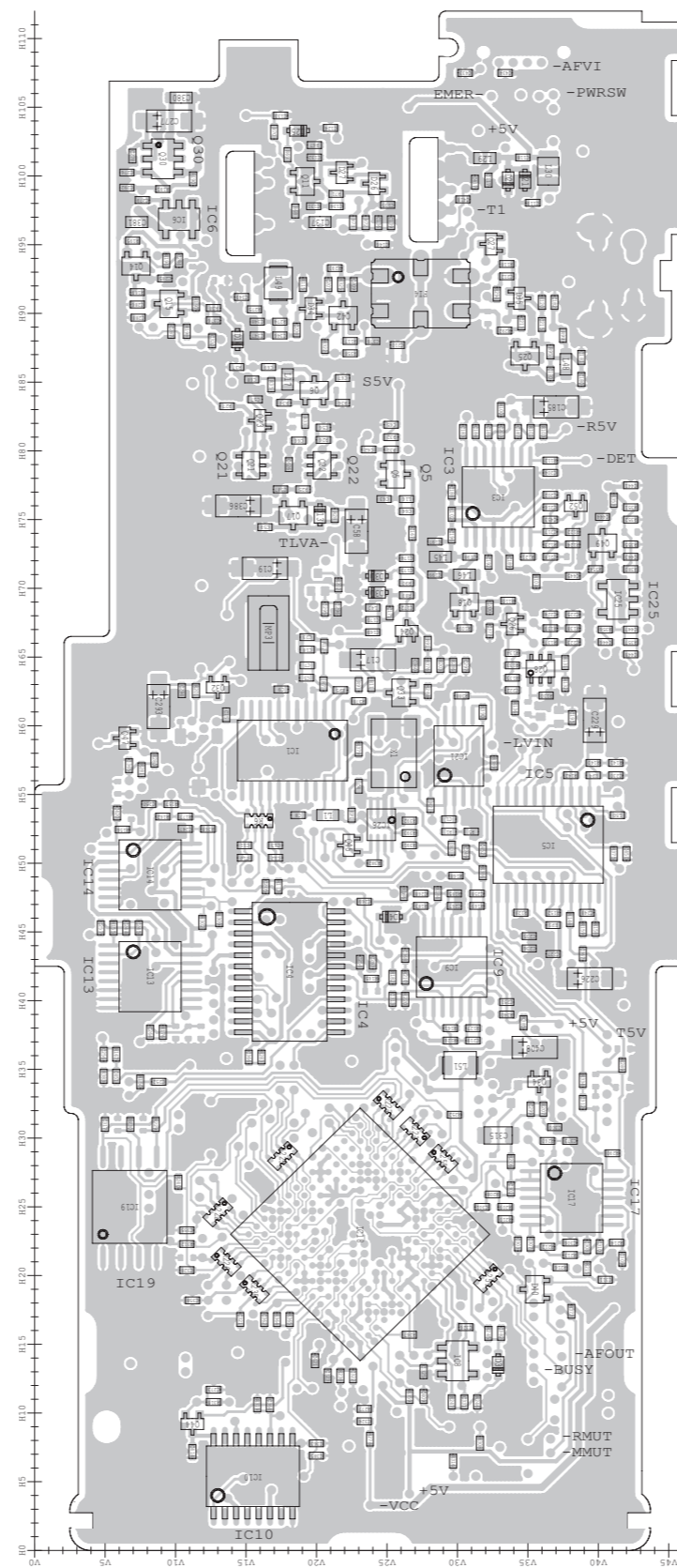

• FRONT-A UNIT (BOTTOM VIEW)

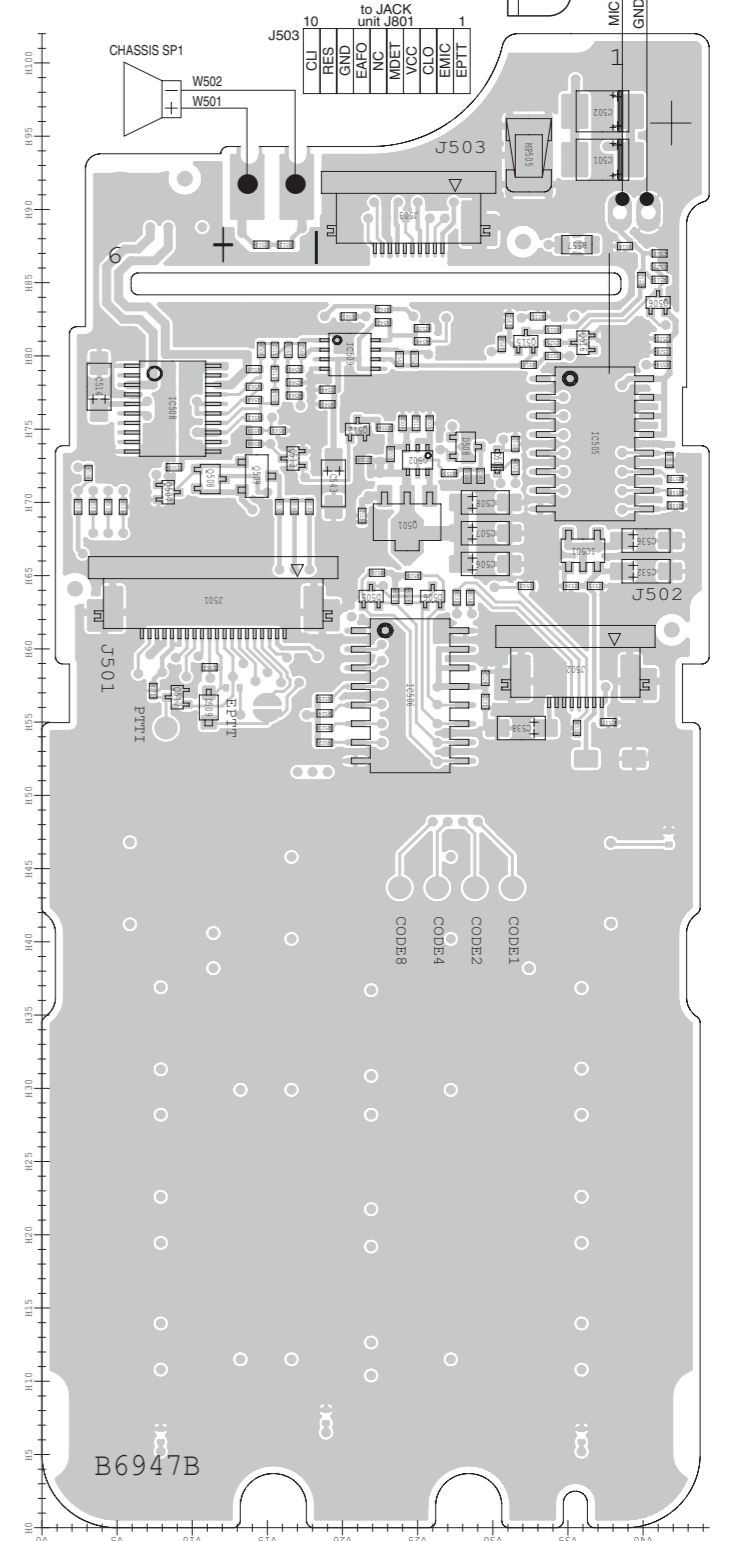

20	GND	1
	MDET	
	VCC	
	AS+	
	AS-	
	CLO	
	RES	
	FSDA	
	PITSW	
	PTTI	
	RR	
	CLI	
	AFONO	
	URES	
	EPTT	
	AF	
	MCIN	
	GND	

to MAIN unit J3

8	GND	1
	AS+	
	AS-	
	RES	
	TSCL	
	GND	
	CDT V	

to LCD

The combination of this side and the bottom side shows the board layout in the same configuration as the actual P.C.Board.

VOLTAGE DIAGRAM

• FRONT UNIT (for F3060 series)

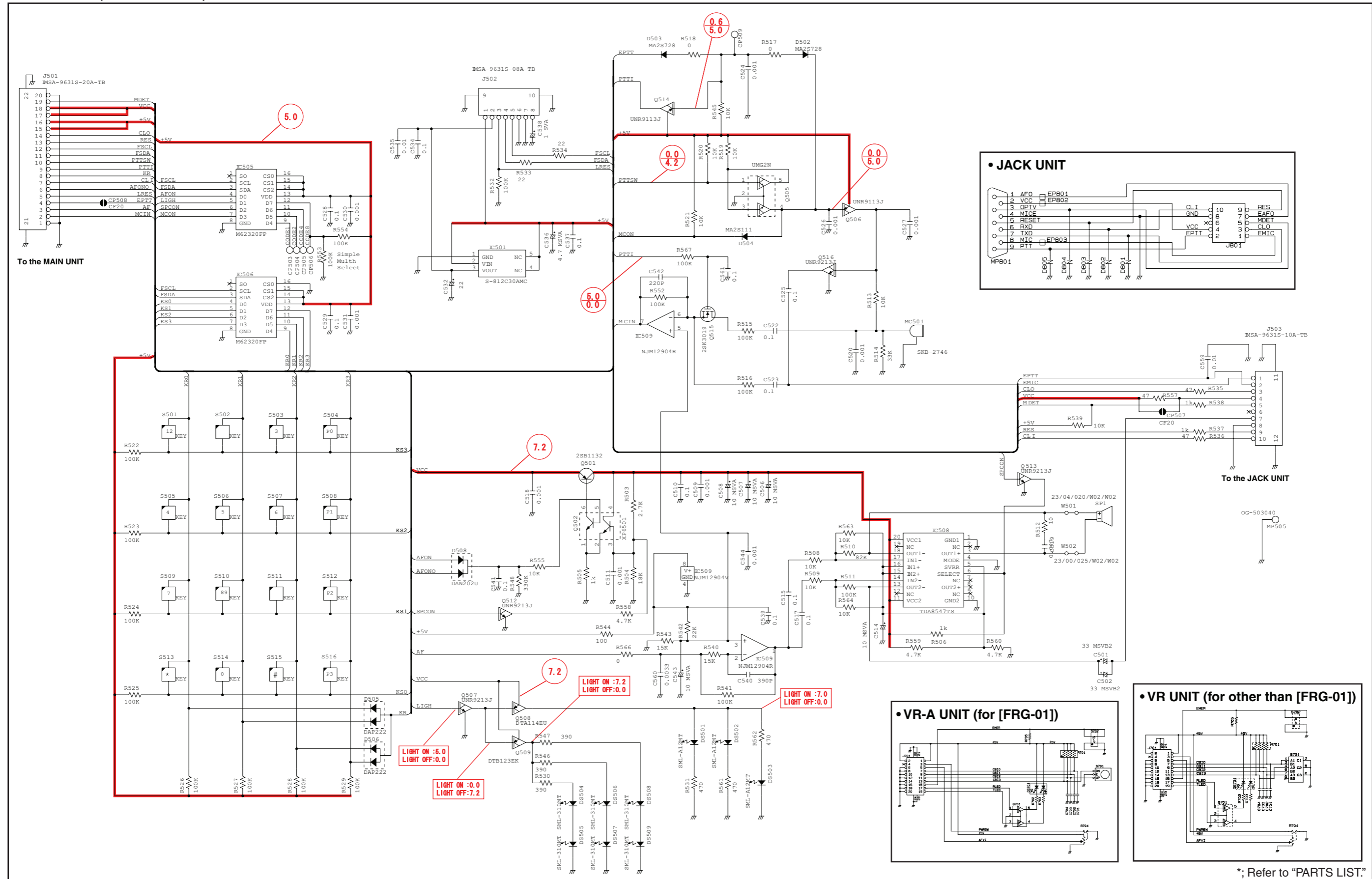

*; Refer to "PARTS LIST."

• FRONT-A UNIT (for F3160 series)

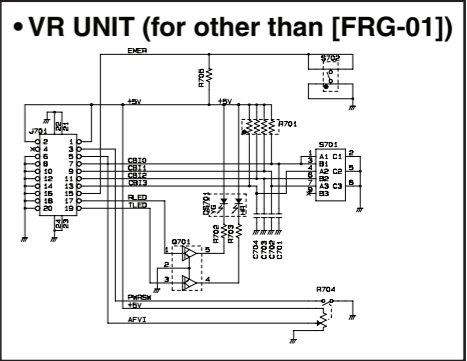
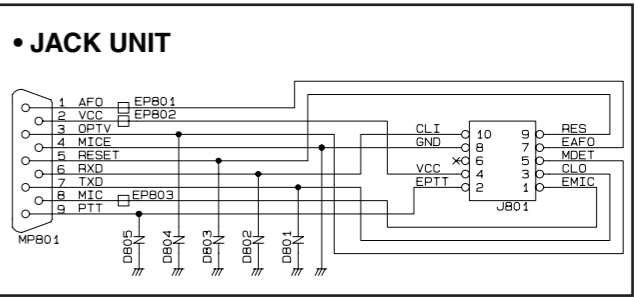
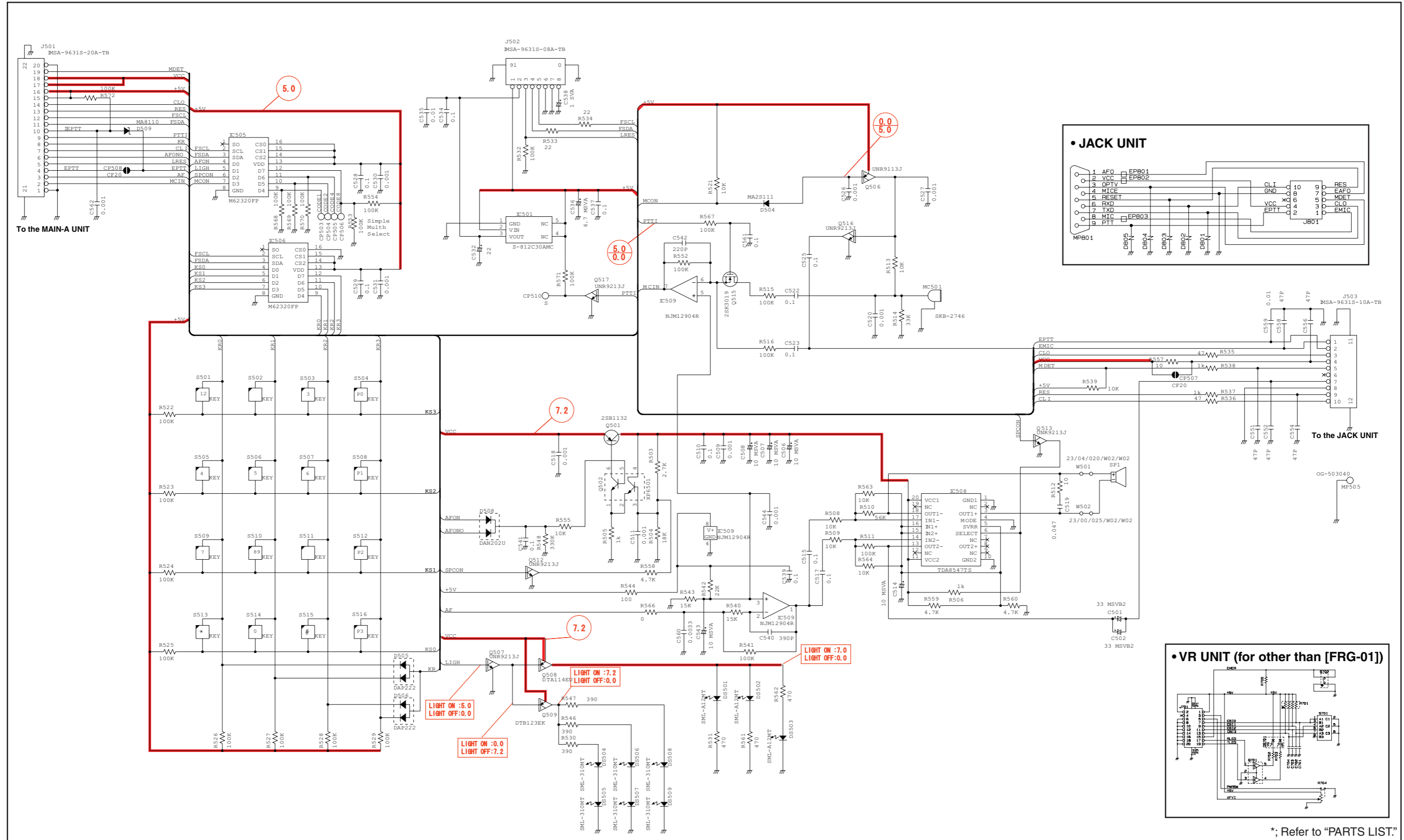

*; Refer to "PARTS LIST."

• MAIN UNIT (for F3060 series)

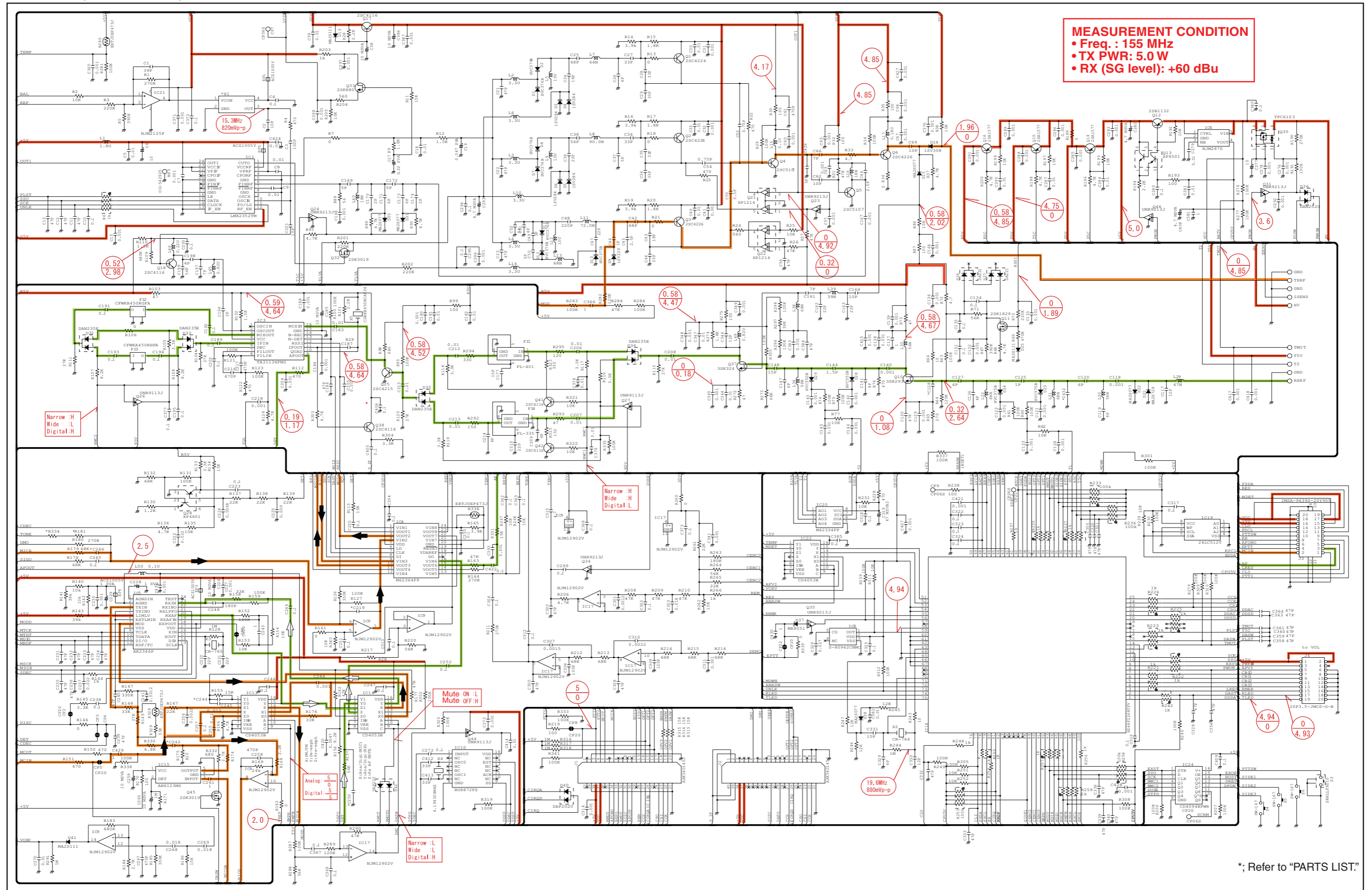

• MAIN-A UNIT (for F3160 series)

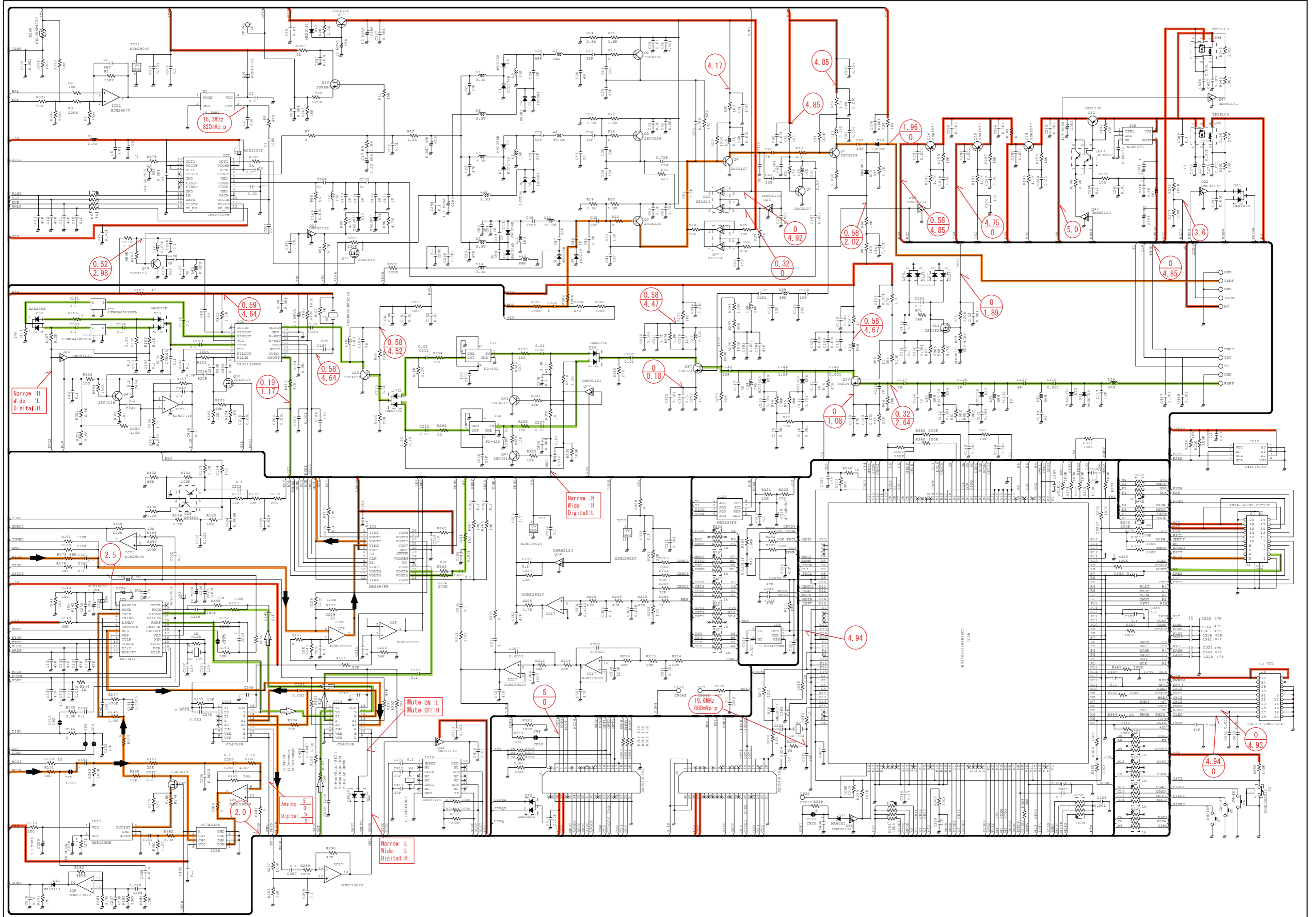

• RF UNIT

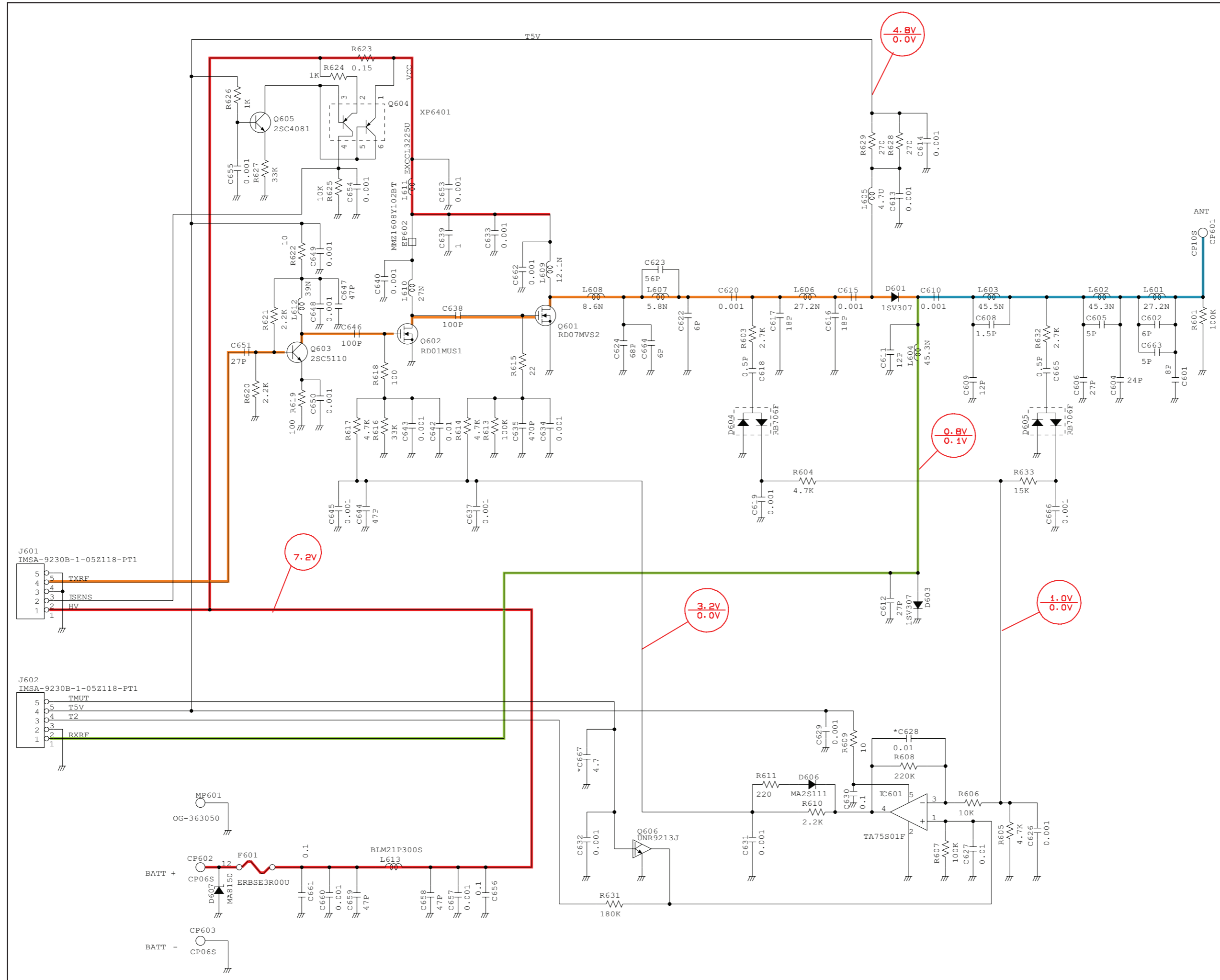



SERVICE MANUAL

VHF TRANSCEIVER

IC-F3061T/S
IC-F3062T/S
IC-F3063T/S
IC-F3161T/S
IC-F3162T/S
IC-F3163T/S
IC-F3161DT/DS

S-14223HZ-C1-②
Mar. 2008

INTRODUCTION

This service manual describes the latest service information for the **IC-F3061/62/63/T/S**, **IC-F3161/62/63/T/S** and **IC-F3163DT/DS** VHF TRANSCEIVER at the time of publication.

MODEL	SYMBOL	CHANNEL SPACING	KEY PAD	Etc.
IC-F3061T	[USA-01]	15.0/30.0 kHz	10-key	-
IC-F3063T	[GEN-01]	12.5/25.0 kHz		
IC-F3062T	[EUR-01]	12.5/20.0/25.0 kHz		
IC-F3061S	[USA-01]	15.0/30.0 kHz	4-key	
IC-F3063S	[GEN-01]	12.5/25.0 kHz		
IC-F3062S	[EUR-01]	12.5/20.0/25.0 kHz		
IC-F3062S	[FRG-01]	20.0 kHz		BOS compatible
IC-F3161T	[USA-01]	15.0/30.0 kHz	10-key	MDC compatible
IC-F3163T	[EXP-01]	12.5/25.0 kHz		
IC-F3162T	[EUR-01]	12.5/20.0/25.0 kHz		
IC-F3161S	[USA-01]	15.0/30.0 kHz	4-key	
IC-F3163S	[EXP-01]	12.5/25.0 kHz		
IC-F3162S	[EUR-01]	12.5/20.0/25.0 kHz		
IC-F3161DT	[USA-01]	6.25/15.0/30.0 kHz	10-key	UT-126H pre-installed
IC-F3161DS			4-key	

CAUTION

NEVER connect the transceiver to an AC outlet or to a DC power supply that uses more than 7.2 V. This will ruin the transceiver.

DO NOT expose the transceiver to rain, snow or any liquids.

DO NOT reverse the polarities of the power supply when connecting the transceiver.

DO NOT apply an RF signal of more than 20 dBm (100 mW) to the antenna connector. This could damage the transceiver's front-end.

ORDERING PARTS

Be sure to include the following four points when ordering replacement parts:

1. 10-digit Icom parts numbers
2. Component name
3. Equipment model name and unit name
4. Quantity required

<ORDER EXAMPLE>

5030002830 LCD M4-0078TAY-2 IC-F3061T Front unit 5 pieces
8810009220 Screw PH B0 M2×8 ZK (BT) IC-F3061T Chassis 10 pieces

Addresses are provided on the inside back cover for your convenience.

Icom, Icom Inc. and ICOM logo are registered trademarks of Icom Incorporated (Japan) in the United States, the United Kingdom, Germany, France, Spain, Russia and/or other countries.



(IC-F3061T)

To upgrade quality, any electrical or mechanical parts and internal circuits are subject to change without notice or obligation.

REPAIR NOTES

1. Make sure the problem is internal before disassembling the transceiver.
2. **DO NOT** open the transceiver until the transceiver is disconnected from its power source.
3. **DO NOT** force any of the variable components. Turn them slowly and smoothly.
4. **DO NOT** short any circuits or electronic parts. An insulated tuning tool **MUST** be used for all adjustments.
5. **DO NOT** keep power ON for a long time when the transceiver is defective.
6. **DO NOT** transmit power into a Standard Signal Generator or a Sweep Generator.
7. **ALWAYS** connect a 50 dB to 60 dB attenuator between the transceiver and a Deviation Meter or Spectrum Analyzer when using such test equipment.
8. **READ** the instructions of test equipment thoroughly before connecting a test equipment to the transceiver.

CONTENTS

SECTION 1 SPECIFICATIONS

SECTION 2 INSIDE VIEWS

SECTION 3 DISASSEMBLY INSTRUCTIONS

SECTION 4 OPTIONAL UNIT INSTALLATION

SECTION 5 CIRCUIT DESCRIPITON

5-1	RECEIVER CIRCUITS.....	5-1
5-2	TRANSMITTER CIRCUITS.....	5-2
5-3	PLL CIRCUITS.....	5-3
5-4	POWER SUPPLY CIRCUITS.....	5-4
5-5	PORT ALLOCATIONS.....	5-5

SECTION 6 ADJUSTMENT PROCEDURES

6-1	PREPARATION.....	6-1
6-2	FREQUENCY ADJUSTMENT.....	6-4
6-3	TRANSMIT ADJUSTMENT.....	6-5
6-4	RECEIVE ADJUSTMENT.....	6-6

SECTION 7 PARTS LIST

SECTION 8 MECHANICAL PARTS AND DISASSEMBLY

SECTION 9 BOARD LAYOUTS

SECTION 10 BLOCK DIAGRAM

SECTION 11 VOLTAGE DIAGRAM

SECTION 12 BC-160 (Optional)

SECTION 1

SPECIFICATIONS

		[USA], [GEN], [EXP]	[EUR], [FRG]	
GENERAL	• Frequency coverage	136–174 MHz		
	• Type of emission	Wide	16K0F3E (25.0 kHz/30.0 kHz)	16K0F3E (25.0 kHz) [EUR-01]
		Middle	–	14K0F3E (20.0 kHz) [EUR-01], [FRG-01]
		Narrow	11K0F3E, 11K0F7E/D* (15.0 kHz) 8K50F3E, 8K10F1E/D* (12.5 kHz) 4K00F1E/D* (6.25 kHz)	8K50F3E (12.5 kHz) [EUR-01] 4K00F1E/D* (6.25 kHz) [EUR-01]
	• Number of programable channels	512 channels (128 zones)		
	• Antenna impedance	50 Ω (nominal)		
	• Operating temperature range	–22°F to +140°F	–25°C to +55°C	
	• Power supply requirement	Specified Icom's battery packs only (Operatable voltage; 7.2 V DC negative ground)		
	• Current drain (approx.)	RX	Stand-by	100 mA 150 mA (with UT-119H/UT-126H)
			Max.audio	600 mA
TX		at 5 W	1.5 A	
		at 1 W	0.7 A	
• Dimensions (with BP-232N, approx.)	2 3/32 (W) × 5 11/32 (H) × 1 17/32 (D) in	53.0 (W) × 136.0 (H) × 38.5 (D) mm		
• Weight (with BP-232, approx.)	12 oz	340 g		
TRANSMITTER	• Transmit output power	5 W (High), 2 W (Low2), 1 W (Low1)		
	• Modulation	Variable reactance frequency modulation		
	• Max. frequency deviation	Wide	±5.0 kHz	
		Middle	–	±4.0 kHz
		Narrow	±2.5 kHz	
	• Frequency error	±1.0 ppm	±1.5 kHz	
	• Spurious emission	75 dB typ.	0.25 μW (≤1 GHz), 1.00 μW (>1 GHz)	
	• Adjacent channel power	Wide	More than 70 dB (80 dB typ.)	
		Middle	–	More than 70 dB (80 dB typ.)
		Narrow	More than 60 dB (70 dB typ.)	
	• Audio harmonic distortion	3% typ. (with 1 kHz AF 40% deviation)		
	• FM hum and noise (without CCITT filter)	Wide	More than 40 dB (46 dB typ.)	–
		Narrow	More than 34 dB (40 dB typ.)	–
• Limiting charact of modulation	60–100% of max. deviation			
• Microphone impedance	2.2 kΩ			
RECEIVER	• Receive system	Double conversion superheterodyne		
	• Intermediate frequencies	1st IF; 46.35 MHz, 2nd IF; 450 kHz		
	• Sensitivity	0.25 μV typ. at 12 dB SINAD	– 4 dBμV (EMF) typ. at 20 dB SINAD	
	• Squelch sensitivity (at threshold)	0.25 μV typ.		
	• Adjacent channel selectivity	Wide	More than 70 dB (75 dB typ.)	
		Middle	–	More than 70 dB (75 dB typ.)
		Narrow	More than 65 dB (68 dB typ.)	
	• Spurious response	More than 70 dB		
	• Intermodulation	More than 70 dB (74 dB typ.)	More than 65 dB (67 dB typ.)	
	• Hum and Noise (without CCITT filter)	Wide	More than 40 dB (46 dB typ.)	–
		Narrow	More than 34 dB (40 dB typ.)	–
	• Residual modulation (with CCITT filter)	Wide	–	More than 45 dB (55 dB typ.)
Middle		–	More than 43 dB (53 dB typ.)	
Narrow		–	More than 40 dB (50 dB typ.)	
• Audio output power	0.5 W typ. at 5% distortion with an 8 Ω load			
• Audio output impedance	8 Ω			

*; Optional digital unit is necessary.

Specifications are measured in accordance with EIA-152-C/204D, TIA-603 (for [USA], [GEN], [EXP]) or EN 300 086 (for [EUR], [FRG]).
All stated specifications are subject to change without notice or obligation.

• FRONT UNIT

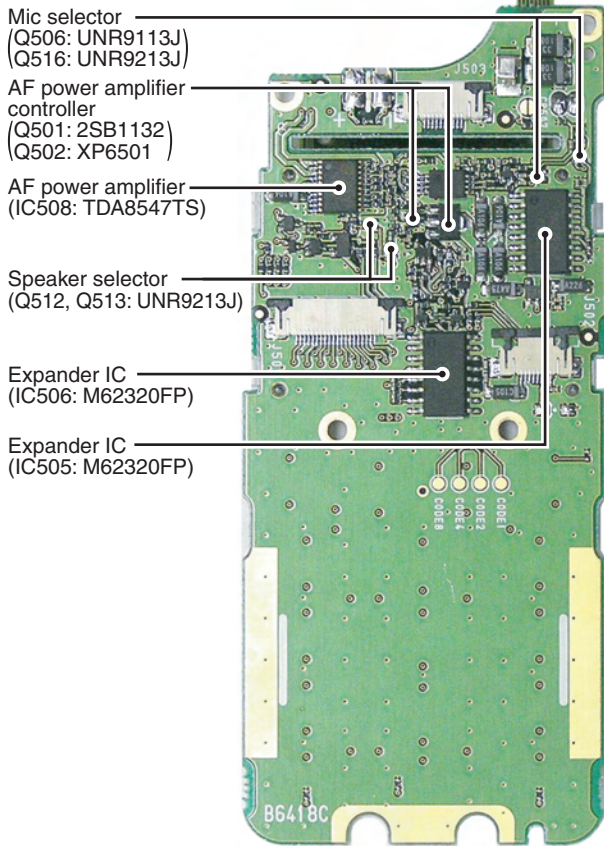

• RF UNIT (Top view)

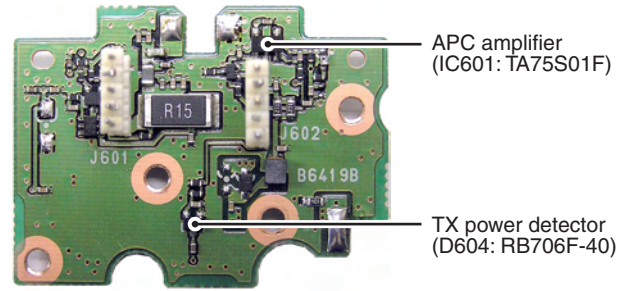

• RF UNIT (Bottom view)

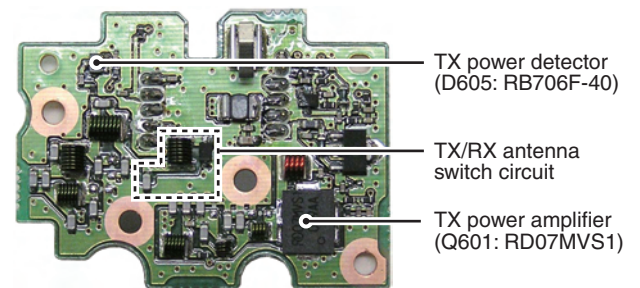

• MAIN UNIT (Top view)

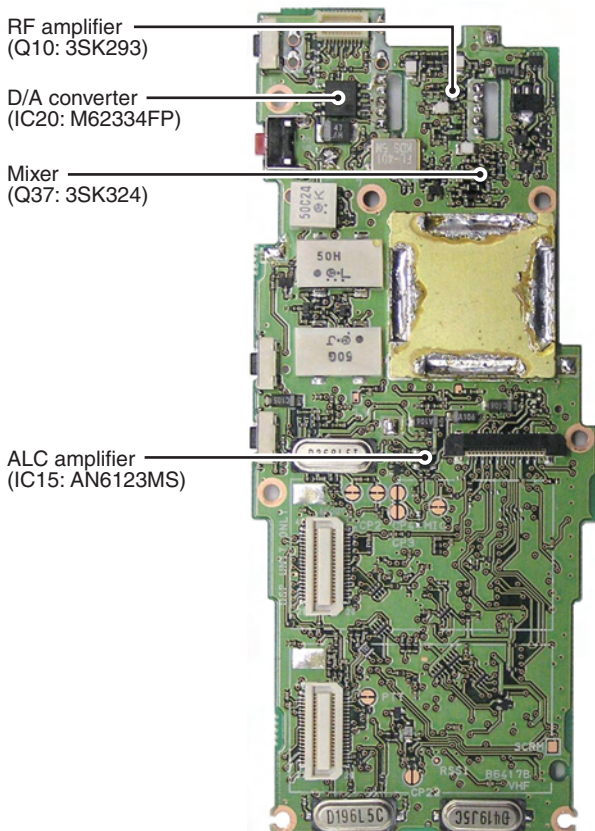

• MAIN UNIT (Bottom view)

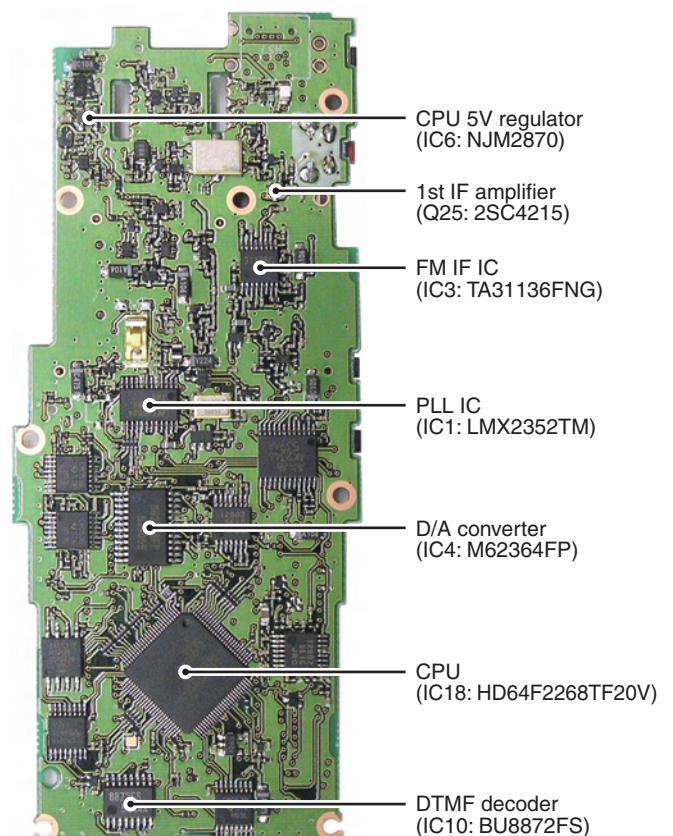

SECTION 3 DISASSEMBLY INSTRUCTION

• REMOVING THE CHASSIS UNIT

- ① Unscrew 1 nut (A), and remove 2 knobs (B) and (C).
- ② Unscrew 2 screws (D).
- ③ Take off the chassis unit in the direction of the arrow.
- ④ Disconnect the flat cable (E) form J501.
- ⑤ Remove the seal (F).
- ⑥ Unscrew 2 nuts (G) and remove the plate (H).

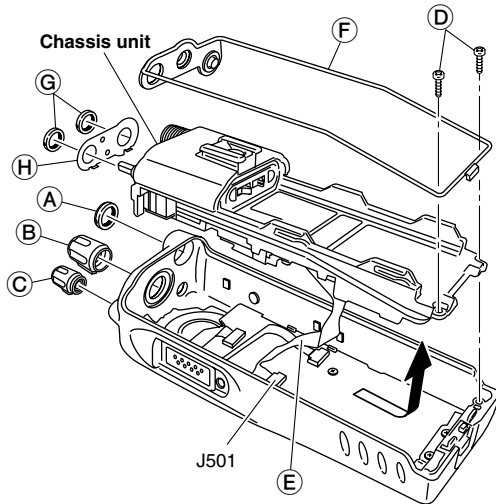

• REMOVING THE RF UNIT

- ① Unsolder 3 points (A).
- ② Unscrew 4 screws (B) and remove the RF unit from the chassis.

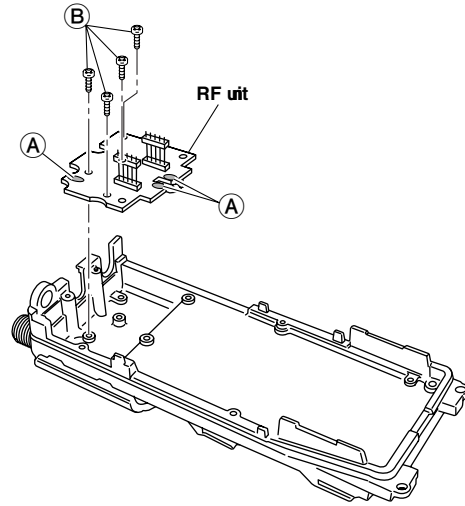

• REMOVING THE MAIN UNIT

- ① Unsolder 1 point (A).
- ② Unscrew 1 screw (B) and remove the VR unit.
- ③ Unsolder 5 points (C) and remove the shield plate (D).
- ④ Unsolder 10 points (E).
- ⑤ Unscrew 7 screws (F) and remove the MAIN unit from the chassis.

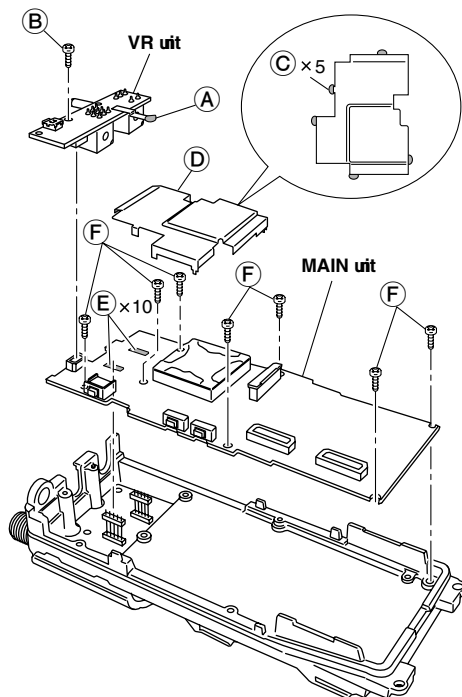

• REMOVING THE FRONT UNIT

- ① Disconnect the flat cable (A) from J503.
- ② Unsolder 2 points (B).
- ③ Unscrew 6 screws (C) and remove the plate (D) and FRONT unit.

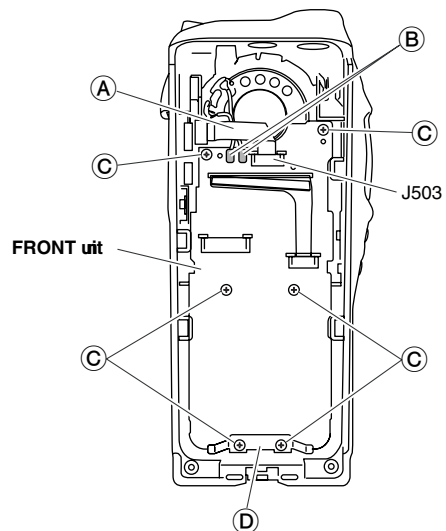

SECTION 4 OPTIONAL UNIT INSTALLATION

CAUTION! Optional unit installation should be done at authorized Icom service center only.
 The waterproof capability of the transceiver cannot be guaranteed if you install an unit yourself, or have it done at a non-authorized dealer/service center.

Install the optional unit as follows.

- ① Rotate [VOL] to turn the power OFF, and remove the battery pack.
- ② Remove the antenna and antenna nut (A).
- ③ Remove the rotary selector (B) and volume control (C).
- ④ Unscrew two screws (D), then take off the chassis from the front panel in the direction of the arrow.
BE CAREFUL! Flat cable is connected between the MAIN unit on the chassis and front panel.

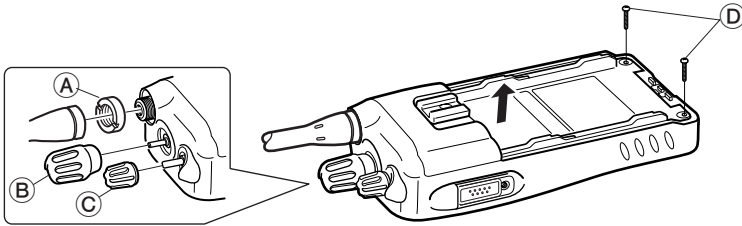

- ⑤ Install the optional unit as below.

• UT-96R, UT-109R and UT-110R installation*

DO NOT attach the unit to the connector "J2." Otherwise no TX modulation or AF output is available.

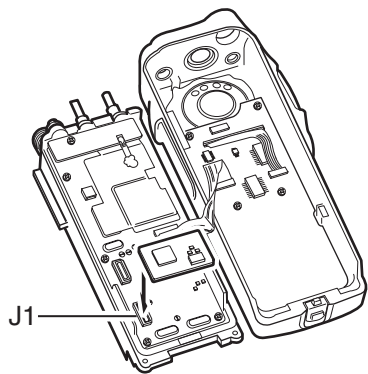

• UT-119H and UT-126H installation

DO NOT attach the unit to the connector "J1." Otherwise no TX modulation or AF output is available.

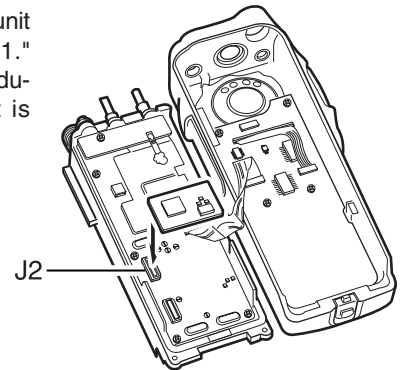

*; The following PC board modification is required when installing optional UT-109R and UT-110R.

Cut the pattern on the PC board at "MIC" and "AFOUT" as shown below.

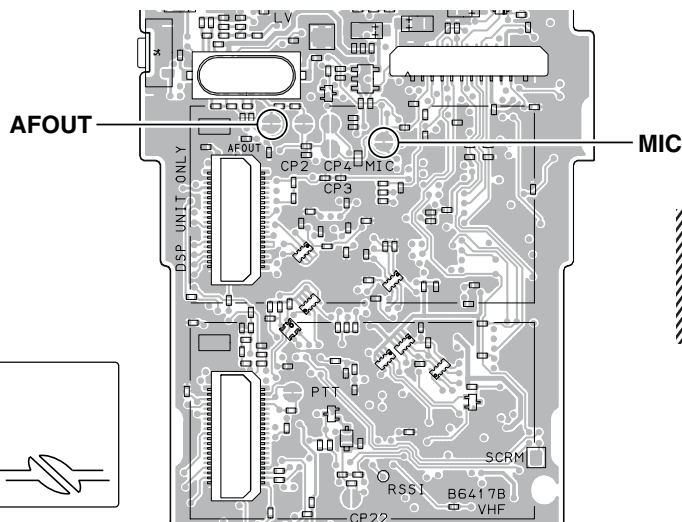

NOTE: When uninstalling the unit
 Be sure to re-solder the disconnected points as below when you remove the unit. Otherwise, no TX modulation or AF output is available.

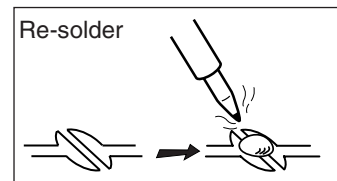
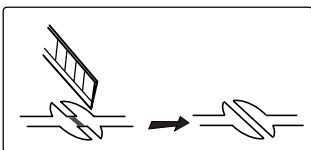

5-1 RECEIVER CIRCUITS

5-1-1 ANTENNA SWITCH (MAIN and RF UNITS)

The received signals from the antenna connector are passed through the antenna switch which toggles the receive (RX) line and transmit (TX) line.

The received signals from the antenna connector are passed through the low-pass filter (LPF; L601–L603, C601, C602, C604–C606, C608, C609, C663), and the antenna switch (D601 and D603 are OFF).

While transmitting, the voltage on the T5V line is applied to D601 and D603, and these are ON. Thus the TX line is connected to the antenna. Simultaneously, the RX line is connected to the GND to prevent transmit signal entering.

While receiving, no voltage is applied to the D601 and D603, and these are OFF. Thus the TX line and the antenna is disconnected to prevent received signals entering. Simultaneously, the RX line is disconnected from the GND and the received signals are passed through the LPF (RF UNIT; L604, C611, C612, MAIN UNIT; L29, C117).

The filtered signals from the LPF (RF UNIT; L604, C611, C612, MAIN UNIT; L29, C117) are then applied to the RF circuit via the two staged tunable bandpass filter (BPF; D23, D24, L31, L32, C120–C122, C125–C127).

5-1-2 RF CIRCUIT (MAIN UNIT)

The received signals are filtered and amplified at the RF circuit.

The filtered signals are applied to the RF amplifier (Q10). The amplified signals are applied to the 1st mixer (Q37) via another two-staged BPF (D28, D29, L33, L34, C140–C144, C147).

5-1-3 1st IF CIRCUITS

The received signals are converted into the 1st IF signal, and amplified at the 1st IF circuits.

The filtered signals from the RF circuit are converted into the 46.35 MHz 1st IF signal by being mixed with the 1st Local Oscillator (LO) signals from the VCO (155 MHz and below; Q1, D1–D4, 155 MHz and higher; Q2, D5–D8) at the 1st mixer (Q37).

The converted 1st IF signal is passed through the 1st IF filter (in wide mode; FI1, in narrow mode; FI4) via the bandwidth switch (D34), to remove adjacent signals. The filtered signal is applied to the 1st IF amplifier (Q25) via another bandwidth switch (D35). The amplified 1st IF signal is then applied to the FM IF IC (IC3, pin 16).

5-1-4 2nd IF AND DEMODULATOR CIRCUITS (MAIN UNIT)

The 1st IF signal is converted into the 2nd IF signal, and demodulated.

The 1st IF signal from the 1st IF amplifier (Q25) is applied to the 2nd IF mixer in the FM IF IC (IC3, pin 6). And the 1st IF signal is converted into the 450 kHz 2nd IF signal by being mixed with the 2nd LO signal from the reference frequency oscillator (X1) via the tripler (Q18).

The converted 2nd IF signal is output from pin 3, and passed through the 2nd IF filter (FI2) to suppress sideband noise. In narrow mode, the 2nd IF signal is also passed through another 2nd IF filter (FI3) via bandwidth switches (D32, D33).

The filtered 2nd IF signal is applied to the limiter amplifier in the FM IF IC (IC3, pin 5). The amplified 2nd IF signal is FM-demodulated at the quadrature detector (X5, IC3, pins 10, 11) and output from pin 9. The demodulated AF signals are then applied to the AF circuits.

5-1-5 AF CIRCUITS (FRONT and MAIN UNITS)

The demodulated AF signals from the FM IF IC are amplified and filtered at AF circuits. This transceiver employs the base band IC for audio signal processing for both transmit and receive. The base band IC is an audio processor and composed of pre-amplifier, compressor, expander, scrambler, etc. in its package.

The demodulated AF signals from the FM IF IC (IC3, pin 9) are applied to the base band IC (IC5, 23) via the Digital/Analog switch (IC14, pins 2, 15).

The applied AF signals are amplified at the amplifier (RXA1) and level adjusted at the volume controller (VR3), then suppressed unwanted 3 kHz and higher audio signals at LPF. The filtered AF signals are applied or bypassed the TX/RX HPF, scrambler, de-emphasis sections in sequence.

• 2nd IF AND DEMODULATOR CIRCUITS

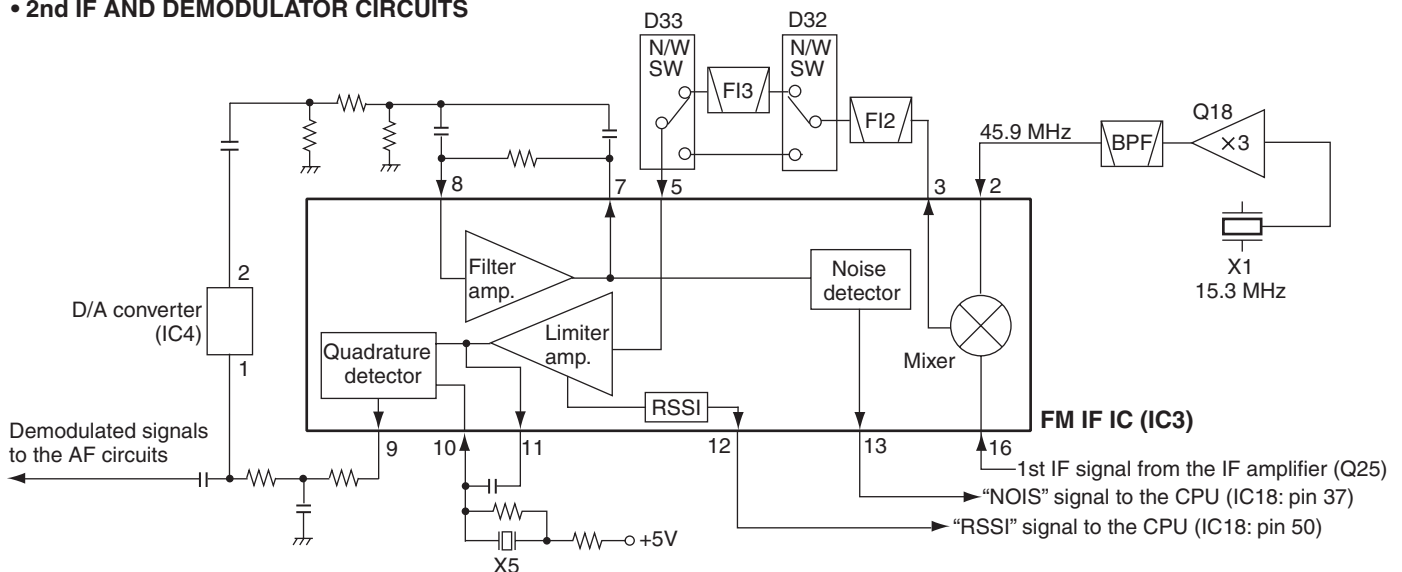

The TX/RX HPF filters out 250 Hz and lower audio signals, and the de-emphasis circuit obtains -6 dB/oct of audio characteristics. The expander expands the compressed audio signals and also noise reduction function is provided.

The AF signals are then level adjusted at the volume controller (VR4) and amplified at the amplifier (RXA2). The amplified AF signals are output from pin 20 and passed through another de-emphasis circuit (IC13, pins 2, 15), and then applied to the D/A converter (IC4, pin 16) for level adjustment via the AF mute switch (IC14, pins 3, 4).

The level-adjusted AF signals are applied to the AF amplifier (FRONT UNIT; IC509, pin 2). The amplified AF signals are output from pin 1, and applied to the AF power amplifier (IC508, pin 17) to obtain 0.5 W of AF output power. The power-amplified AF signals are output from pin 18, and then applied to the internal speaker.

If an external speaker-microphone or headset is attached to the multi-connector (JACK UNIT; MP801), the AF signals from the AF amplifier (IC509, pin 1) are applied to the AF power amplifier (IC508, pin 14). The power-amplified AF signals are then output from pin 13, and applied to the multi-connector (JACK UNIT; MP801).

5-1-5 SQUELCH CIRCUIT

• NOISE SQUELCH

The squelch mutes the AF output signals when no RF signals are received. By detecting noise components (30 kHz and higher signals) in the demodulated AF signals, the squelch circuit toggles the AF power amplifier ON and OFF.

A portion of the demodulated AF signals from the FM IF IC (IC3, pin 9) are applied to the D/A converter (IC4, pin 1) for level adjustment (squelch threshold adjustment). The level-adjusted AF signals are output from pin 2 and passed through the noise filter (IC3, pins 7, 8, R121–R124, C216–C218). The filtered noise signals are amplified the noise components only.

The amplified noise components are converted into the pulse-type signal at the noise detector section, and output from pin 13 as the "NOIS" signal. The signal is applied to the CPU (IC18, pin 37). Then the CPU outputs serial data to the expand IC (FRON UNIT; IC505, pin 3), and the expand IC outputs "AFON" signal from pin 4 according to the "NOIS" signal level, to the AF power amplifier controller (FRONT UNIT; Q501, Q502, D508). The AF power amplifier controller toggles AF power amplifier (FRONT UNIT; IC508) ON and OFF according to the "AFON" signal.

• TONE SQUELCH

The tone squelch circuit detects tone signals and opens the squelch only when receiving a signal containing a matched sub audible tone. When the tone squelch is in use, and a signal with a mismatched or no sub audible tone is received, the tone squelch circuit mutes the AF signals even when the noise squelch is open.

• CTCSS/DTCS

A portion of the demodulated AF signals are passed through the active LPF (Q28) to filters CTCSS/DTCS signal. The filtered signal is applied to the CPU (IC18, pin 46). The CPU compares the applied signal and the set CTCSS/DTCS, then output the serial data to the expand IC (FRON UNIT; IC505, pin 3), and the expand IC outputs "AFON" signal from pin 4 to the AF power amplifier controller (Q501, Q502, D508).

• 2/5 TONE

2/5 tone signals in the demodulated AF signals are passed through the LPF in the base band IC (IC5) and output from pin 21, then applied to the CPU (IC18, pin 45) and decoded.

• DTMF

DTMF signals in the demodulated AF signals are passed through the LPF in the base band IC (IC5) and output from pin 21, then applied to the DTMF decoder (IC10, pin 1) and decoded.

5-2 TRANSMITTER CIRCUITS

5-2-1 MICROPHONE AMPLIFIER CIRCUITS (MAIN UNIT)

The AF signals from the microphone (MIC signals) are filtered and level-adjusted at microphone amplifier circuits.

MIC signals from the microphone are passed through the microphone switch (FRON UNIT; Q515). The microphone switch selects the AF signals from the internal microphone (FRON UNIT; MC1) or from an external microphone.

MIC signals from the microphone switch (FRON UNIT; Q515) are applied to the microphone amplifier (FRON UNIT; IC509, pin 6), and amplified AF signals are output from pin 7, and passed through the pre-emphasis circuit (IC13, pins 4, 5) to obtain $+6$ dB/oct of frequency characteristic. The pre-emphasized MIC signals are then applied to the microphone amplifier (IC9, pin 9). And the amplified MIC signals are output from pin 8, and applied to the D/A converter (IC4, pin 9) for level adjustment (=microphone sensitivity adjustment). The level-adjusted MIC signals are output from pin 10, and applied to the ALC (Automatic Level Control) circuit (IC15, pin 3) which limits the amplitude of the MIC signals to prevent over deviation. The amplitude-limited MIC signals are output from pin 5, then applied to the base band IC (IC5, pin 3).

The applied MIC signals are amplified at the amplifier (TXA1), and level adjusted at the volume controller (VR1). The level adjusted MIC signals are applied or bypassed the compressor section, pre-emphasis section, TX/RX HPF, de-scrambler, limiter, splatter, in sequence, then applied to another volume controller.

The compressor compresses the MIC signals to provide high S/N ratio for receive side, and the pre-emphasis obtains $+6$ dB/oct audio characteristics. The TX/RX HPF filters out 250 Hz and lower audio signals, the limiter limits its level and the splatter filters out 3 kHz and higher audio signals.

The filtered MIC signals are level adjusted at another volume controller (VR2), and then output from pin 7 via smoothing filter (SMF).

• BASE BAND IC BLOCK DIAGRAM

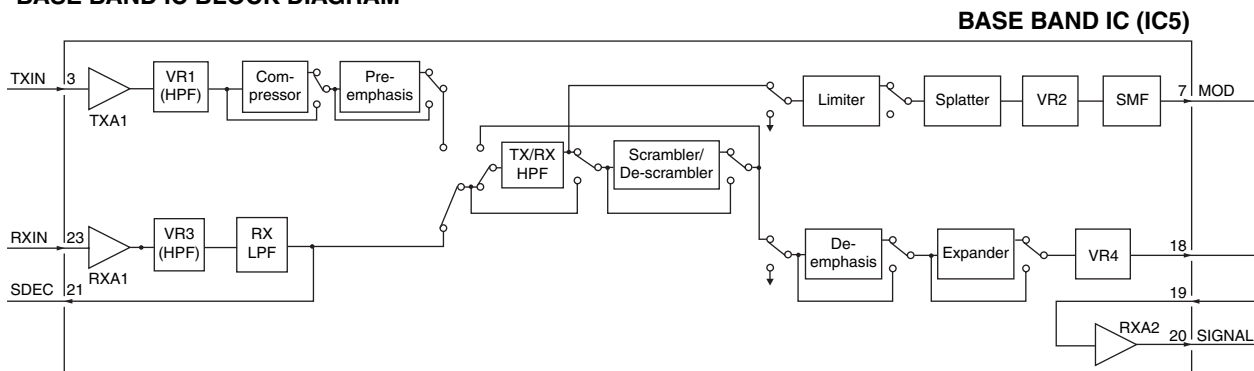

The output AF signals are then passed through the Digital/Analog switch (IC14, pins 12, 14) and applied to the AF mixer (IC9, pin 6) where the MIC signals and Tone signals are mixed with (while CTCSS/DTCS are in use) via the PM/FM switch (IC13, pins 12, 14).

The CTCSS and DTCS signals are generated by the CPU (IC18) and output from pins 89–91. The output signals are passed through the 3 registers (R263–R265) to change its wave form. The wave form changed CTCSS/DTCS signals are passed through the LPF (IC17, pins 1, 3) and the D/A converter (IC4, pins 21, 22) for level adjustment. The level adjusted CTCSS/DTCS signals are then applied to the AF mixer (IC9, pin 6).

2/5 tone and DTMF signals are generated by the CPU (IC18) and output from pin 43. The output signals are passed through two LPF's (IC17, pins 8, 10 and pins 5, 7), then applied to the AF mixer (IC9, pin 6).

The mixed AF signals are output from pin 7 of the AF mixer (IC9) and passed through the D/A converter (IC4, pins 3, 4) for level adjustment (=deviation adjustment), then applied to the modulation circuit (D9) as the modulation signals. The modulation signals are also applied to the reference frequency oscillator (X1) via D/A converter (IC4, pins 11, 12) and AF amplifier (IC21, pins 1, 4).

5-2-2 MODULATION CIRCUIT (MAIN UNIT)

The modulation signals from the microphone amplifier circuits are applied to the D9, and modulate the VCO oscillating signal by changing the reactance of D9. The modulated VCO output signal is buffer-amplified by Q4 and Q6, then applied to transmit amplifiers as a transmit signal via the TX/RX switch (D14 is ON, D15 is OFF).

5-2-3 TRANSMIT AMPLIFIERS (RF UNIT)

The transmit signal from the TX/RX switch (MAIN UNIT; D14 is ON, D15 is OFF) is amplified to the transmit output level by pre-driver (Q603), driver (Q602) and power (Q601) amplifiers.

The power-amplified transmit signal is passed through the two LPF's (L607, L608, C620, C622–C624, C664 and L606, C615–617) to filter off the harmonic components in the transmit signal. The filtered transmit signal is passed through the antenna switching circuit (D601 and D603 are ON), then applied to the antenna connector (CHASSIS; J1) via another LPF (L601–L603, C601, C602, C604–C606, C608, C609, C663).

5-2-4 APC CIRCUIT (RF UNIT)

The APC (Automatic Power Control) circuit stabilizes transmit output power to prevent the transition of the transmit output power level which is caused by load mismatching or heat effect, etc. The APC circuit also selects transmit output power from high, middle and low power.

A portion of the transmit signal is detected by the transmit power detector (D604, D605) to produce a DC voltage corresponding to the transmit output power level. The detected voltage is applied to the APC amplifier (IC601, pin 3). The transmit power setting voltage "T2" from the D/A converter (MAIN UNIT; IC20, pin 2) is applied to another input terminal (pin 1) as the reference voltage.

The APC amplifier compares the detected voltage and reference voltage, and the difference of the voltage is output from pin 4. The output voltage controls the bias of the drive (Q602) and power (Q601) amplifiers to reduce/increase the gain of these amplifiers for stable transmit output power.

The change of transmit output power is carried out by the change of reference voltage "T2," and the transmit power muting is carried out by the TX mute switch (Q606), using the "TMUT" signal from the CPU (IC18, pin 13).

5-2-4 OVER CURRENT DETECTION CIRCUIT (RF UNIT)

The driving current of the drive (Q602) and power (Q601) amplifiers is detected at the current detector (Q604, Q605) by detecting the difference of voltage between both terminals of R623. The detected voltage "ISENS" is applied to the CPU (IC18, pin 47).

In case of the over current, the CPU outputs "TMUT" signal from pin 13 to TX mute switch (Q606) to stop the transmitting for protection of transmit amplifiers (Q601, Q602).

5-3 PLL CIRCUITS

5-3-1 VCO (Voltage Controlled Oscillator) CIRCUITS (MAIN UNIT)

A VCO is a oscillator which its oscillating frequency is controlled by adding voltage (lock voltage).

This transceiver has 3 VCO's; RX VCO1 (Q1, D1–D4), RX VCO2 (Q2, D5–D8) and TX VCO (Q3, D10–D12). The RX VCO1 oscillates the 1st LO signals for 155 MHz and higher, and the RX VCO2 oscillates the 1st LO signals for 155 MHz and lower frequencies. And the TX VCO oscillates the transmit output signal.

• RX VCO1 and RX VCO2

The RX VCO1/RX VCO2 (Q1, D1–D4/Q2, D5–D8) oscillates the 1st LO signals. The output signals are amplified by the buffer amplifiers (Q4, Q6), and applied to the 1st mixer (Q37) via TX/RX switch (D14 is OFF, D15 is ON) and LPF (L38, L39, C161–C164, C383, C384), to be mixed with the received signals to produce the 46.35 MHz 1st IF signal.

• TX VCO

The TX VCO (Q3, D10–D12) oscillates the transmit signal. The output signal is applied to the transmit amplifiers via the buffer amplifiers (Q4, Q6) and TX/RX switch (D14 is ON, D15 is OFF).

• APC CIRCUIT

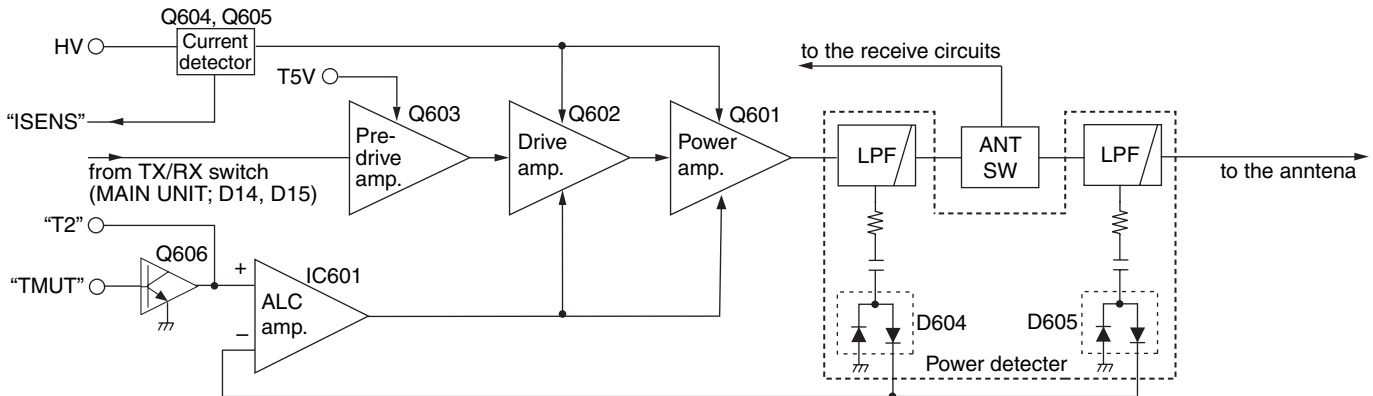

A portion of the each VCO output is applied to the PLL IC (IC1, pin 6) via the buffer amplifiers (Q4, Q5) and the tunable BPF (D30, D31, L40, C170–C174).

5-3-2 PLL CIRCUIT (MAIN UNIT)

The PLL circuit provides stable oscillation of the transmit frequency and receive 1st LO frequency. The PLL output frequency is controlled by the divided ratio (N-data) from the CPU.

The buffer-amplified VCO output signals from the tunable BPF (D30, D31, L40, C170–C174) are applied to the PLL IC (IC1, pin 6). The applied signals are divided at the prescaler and programmable counter according to the “SSO” signal from the CPU (IC18, pin 10). The divided signal is phase-compared with

the reference frequency signal from the reference frequency oscillator (X1), at the phase detector.

The phase difference is output from pin 4 as a pulse type signal after being passed through the internal charge pump. The output signal is converted into the DC voltage (lock voltage) by passing through the loop filter (R7, R9, R12, C17, C18, C20). The lock voltage is applied to the variable capacitors (D1 and D2 of RX VCO1, D7 and D8 of RX VCO2, D11 and D12 of TX VCO) and locked to keep the VCO frequency constant.

If the oscillated signal drifts, its phase changes from that of the reference frequency, causing a lock voltage change to compensate for the drift in the VCO oscillating frequency.

• PLL CIRCUIT

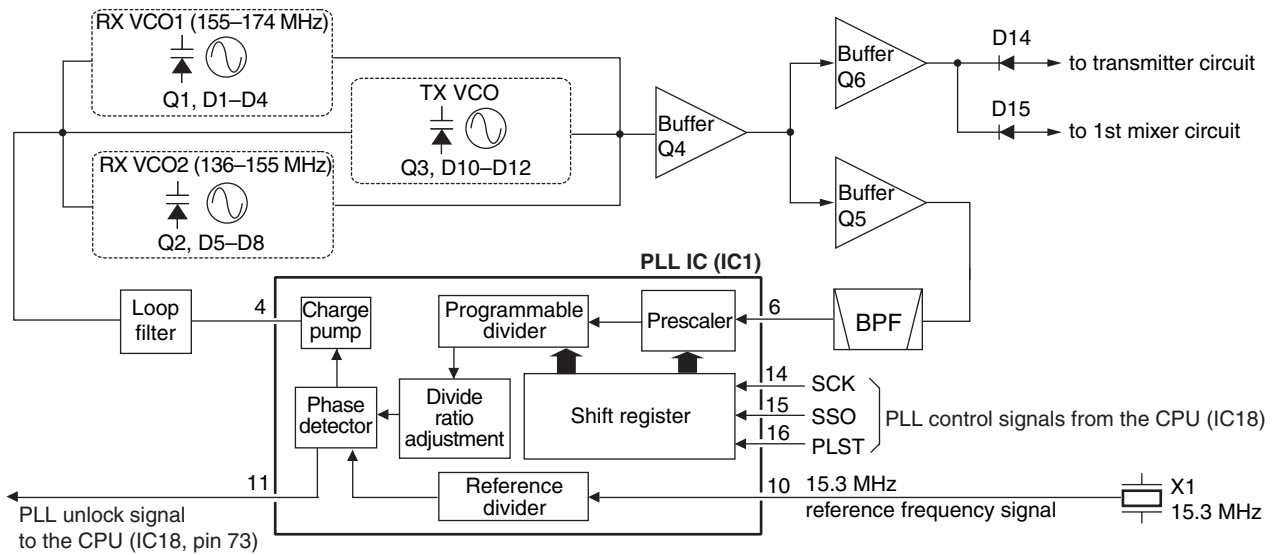

5-4 POWER SUPPLY CIRCUITS (MAIN UNIT)

Voltage from the attached battery pack is routed to whole of the circuit in the transceiver via switches and regulators.

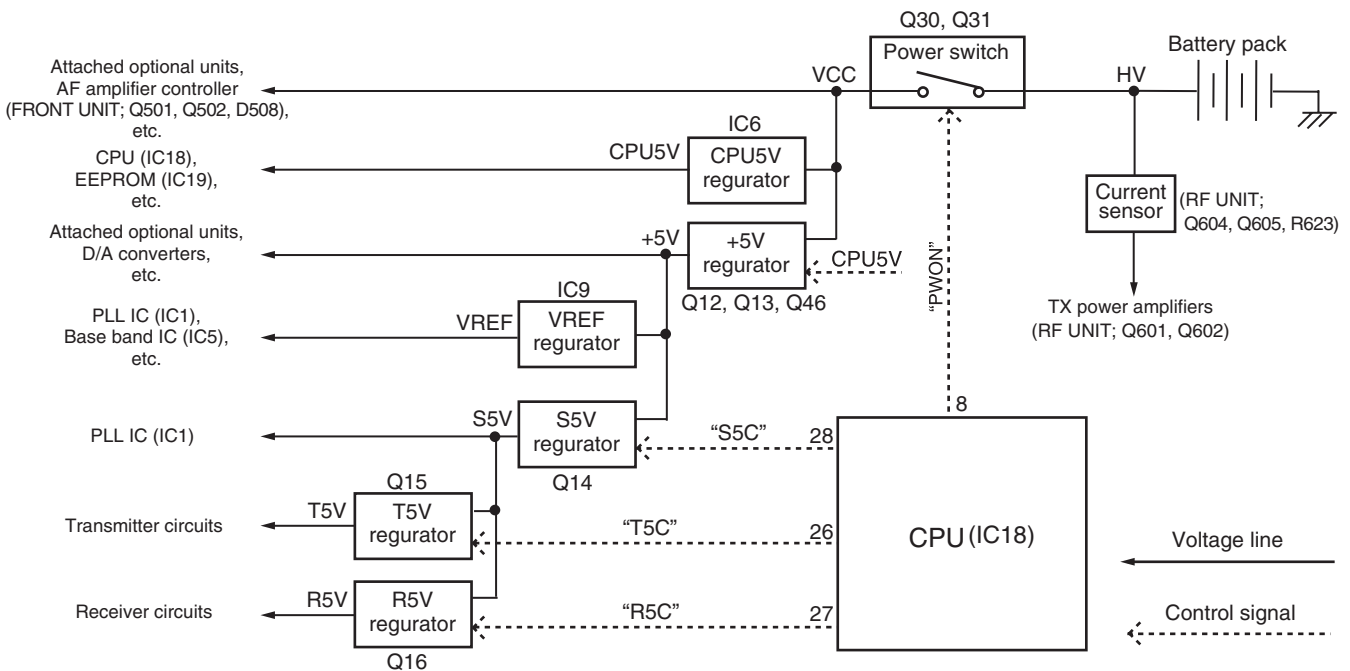

5-5 PORT ALLOCATIONS

5-5-1 CPU (MAIN UNIT; IC18)

Pin No.	Port Name	Description
1	DSDA	Outputs serial data to the D/A converter (IC20, pin 6).
2	DAST	Outputs strobe signal to the D/A converter (IC4, pin 6).
3	SIDE3	Input port for [Side3] key (S4). "Low"=When the key is pushed.
4-7	CBI0-3	Input ports for [ROTARY SELECTOR] (VR UNIT; S701).
10	SSO	Outputs serial data to the PLL IC (IC1, pin 15), D/A converter (IC4, pin 8).
11	SCK	Outputs serial clock signal to the PLL IC (IC1, pin 14), D/A converter (IC4, pin 8).
13	PLST	Outputs PLL strobe signal to the PLL IC (RF UNIT; IC1, pin 16).
15	DASW	Outputs mode (Digital/Analog) switching signal to the D/A converter (IC14, pins 10, 11).
17	TMUT	Outputs transmit mute signal to the transmit mute switch (RF UNIT; Q606).
18	NWC2	Outputs Narrow/Wide mode switching signal to the bandwidth switches (Q26, D32, D33).
19	NWC1	Outputs Narrow/Wide mode switching signal to the bandwidth switches (Q27, Q41, Q42, D34, D35).
20	DDSD	Outputs serial data to the DTMF decode IC (IC10, pin 9).
21	DDAC	Outputs serial clock signal to the DTMF decode IC (IC10, pin 11).
26	T5C	Outputs T5V line control signal to the T5V regulator (Q15). "Low"= While transmitting.
27	R5C	Output R5V line control signal to the R5V regulator (Q16). "Low"= While receiving.
28	S5C	Output S5V line control signal to the S5V regulator (Q14). "Low"=While power save mode.
29	PTTSW	Input port for [PTT] switch (S3). "Low"=When the switch is pushed.
30	SIDE2	Input port for [Side2] key (S5). "Low"=When the key is pushed.
32	RMUT	Outputs mute signal to the AF mute switch (D42).
37	NOIS	Input port for the noise level from the FM IF IC (IC3, pin 13).
38	POSW	Input port for power switch (VR UNIT; R702) from power controller (D36).
39	DDST	Outputs strobe signal to the DTMF decode IC (MAIN UNIT; IC10, pin 14).
40	MTCK	Outputs serial clock signal to the base band IC (MAIN UNIT; IC5, pin 9).
41	PWON	Outputs VCC line control signal to the power switch (Q30, Q31). "Low"=While the power is ON.
43	SENC	Outputs single tone encode signal to the LPF (IC17, pin 10).
44	BEEP	Outputs beep sound to the AF circuits (IC4, pin 13).
45	SDEC	Input port for decoded 2/5 tone and DTMF signals.
46	CDEC	Input port for decoded CTCSS/DTCS signal.
47	ISENS	Input port for power amplifier current detect signal from the current detector (RF UNIT; Q604, Q605).
48	BATV	Input port for remaining battery power.
49	LVIN	Input port for VCO lock voltage.
50	RSSI	Input port for RSSI signal from the FM IF IC (IC3, pin 12).

Pin No.	Port Name	Description
55	EMER	Input port for [Emer] switch (VR UNIT; S702).
70	CSFT	Outputs CPU clock frequency shift signal to the CPU clock oscillator (X2, D38).
71	DUSE	Outputs CTCSS/DTCS select signal to the CTCSS/DTCS switch (Q34).
73	UNLK	Input port for PLL unlock detect signal from the PLL IC (IC1, pin 11).
74	RLED	Outputs RX indicator (VR UNIT; DS701) control signal to the LED driver (VR UNIT; Q701).
75	TLED	Outputs TX indicator (VR UNIT; DS701) control signal to the LED driver (VR UNIT; Q701).
78	FSDA	Outputs serial data to the expand IC (FRONT UNIT; IC505, pin 3).
79	FSCL	Outputs serial clock signal to the expand IC (FRONT UNIT; IC505, pin 3).
81	CIRQ	Input port for external connection detect signal from J1 and J2.
88	SIDE1	Input port for [Side1] key (S6). "Low"=When the key is pushed.
89-91	CENC0-2	Output CTCSS/DTCS signals to the LPF (IC17, pin 3).
92	EMPH	Outputs emphasis characteristic change signal to the D/A converter (IC13, pins 9, 10).
93	MTDT	Outputs serial data to the base band IC (IC5, pin 10).
96	MSCK	Outputs serial clock signal to the base band IC (MAIN UNIT; IC5, pin 13).
97	PMFM	Outputs modulation mode switching signal to the PM/FM switch (IC13, pin 11).
98	ESDA	Outputs serial data to the EEPROM (IC19, pin 5).
99	ESCL	Outputs serial clock signal to the EEPROM (IC19, pin 6).
100	RESL	Input port for reset signal from the reset IC (IC8, pin 1).

5-5-2 D/A CONVERTER (MAIN UNIT; IC20)

Pin No.	Port Name	Description
1	T1	Outputs BPF tuning voltage to the tunable BPF (D23, D24, L31, L32, C120-C122, C125-C127).
2	T2	<ul style="list-style-type: none"> • While receiving Outputs BPF tuning voltage to the tunable BPF (D28, D29, L33, L34, C140-C144, C147). • While transmitting Outputs TX power setting voltage to the APC amplifier (RF UNIT; IC601).
3	TXLVA	Outputs oscillation frequency adjust voltage to the TX VCO (Q3, D10-D12).
4	RXLVA	Outputs oscillation frequency adjust voltage to the RX VCO1/2 (Q1, D1-D4/Q2, D5-D8).

5-5-3 EXPAND IC (FRONT UNIT; IC505)

Pin No.	Port Name	Description
4	AFON	Outputs AF power amplifier (Q508, Q509) control signal to the AF power amplifier controller (Q501, Q502, D508).
5	LIGH	Outputs backlight control signal to the backlight driver (Q507-Q509).
6	SPCON	Outputs internal/external speaker select signal to the SP/ESP switch (Q512, Q513).
7	MCON	Outputs internal/external microphone select signal to the microphone controller (Q505, D504).

SECTION 6 ADJUSTMENT PROCEDURES

6-1 PREPARATION

■ REQUIRED TEST EQUIPMENTS

EQUIPMENT	GRADE AND RANGE	EQUIPMENT	GRADE AND RANGE
Adjustment software (Rev. 1.1 or later)	CS-F3060 ADJ (for F3060 series) CS-F3160/5060 ADJ (for F3160 series)	JIG cable	modified OPC-966/U CLONING CABLE
FM deviation meter	Frequency range : DC–300 MHz Measuring range : 0 to ±10 kHz	Attenuator	Power attenuation : 20 or 30 dB Capacity : 10 W
Frequency counter	Frequency range : 0.1–300 MHz Frequency accuracy : ±1 ppm or better Sensitivity : 100 mV or better	Standard signal generator (SSG)	Frequency range : 0.1–300 MHz Output level : 0.1 μV to 32 mV (–127 to –17 dBm)
RF power meter	Measuring range : 1–10 W Frequency range : 100–300 MHz Impedance : 50 Ω SWR : Better than 1.2 : 1	Oscilloscope	Frequency rang : DC–20 MHz Measuring range : 0.01–20 V
		External speaker	Input impedance : 8 Ω Capacity : 1 W or more

■ SYSTEM REQUIREMENTS

- Microsoft® Windows® 98/98SE/Me/2000/XP
- RS-232C serial port (D-sub 9 pin)

■ ADJUSTMENT SOFTWARE INSTALLATION

- ① Quit all applications when Windows is running.
- ② Insert the CD into the appropriate CD drive.
- ③ Double-click the “Setup.exe” contained in the ‘CS-F3060 ADJ’ folder in the CD drive.
- ④ The “Welcome to the InstallShield Wizard for CS-F3060 ADJ” will appear. Click [Next>].
- ⑤ The “Choose Destination Location” will appear. Then click [Next>] to install the software to the destination folder. (e.g. C:\Program Files\lcom\CS-F3060 ADJ)
- ⑥ After the installation is completed, the “InstallShield Wizard Complete” will appear. Then click [Finish].
- ⑦ Eject the CD.
- ⑧ Program group ‘CS-F3060 ADJ’ appears in the ‘Programs’ folder of the start menu, and ‘CS-F3060 ADJ’ icon appears on the desk top screen.

■ BEFORE STARTING SOFTWARE ADJUSTMENT

Clone the adjustment frequencies into the transceiver, and set the configuration using with the CS-F3060 CLONING SOFTWARE before starting the software adjustment. Otherwise, the software adjustment can not be started.

CAUTION!: **BACK UP** the originally programmed memory data in the transceiver before programming the adjustment frequencies. When program the adjustment frequencies into the transceiver, the transceiver’s memory data will be overwritten and lose original memory data at the same time.

Microsoft and Windows are registered trademarks of Microsoft Corporation in the U.S.A. and other countries.

■ STARTING SOFTWARE ADJUSTMENT

- ① Connect the transceiver and PC with OPC-966 JIG CABLE.
- ② Turn the transceiver power ON.
- ③ Boot up Windows, and click the program group ‘CS-F3060 ADJ’ in the ‘Programs’ folder of the [Start] menu, then CS-F3060 series ADJ’s window appears.
- ④ Click ‘Connect’ on the CS-F3060 ADJ’s window, then appears transceiver’s up-to-date condition.
- ⑤ Set or modify adjustment data as specified.

• ADJUSTMENT FREQUENCY LIST

CH	FREQUENCY	ADJUSTMENT ITEM
1	154.900 MHz	TX power : Low1 Mode : Narrow
2	173.900 MHz	TX power : Low1 Mode : Narrow
3	136.100 MHz	TX power : Low1 Mode : Wide
4	155.000 MHz	TX power : Low1 Mode : Wide
5	155.000 MHz	TX power : Low2 Mode : Wide
6	155.000 MHz	TX power : High Mode : Wide
7	155.000 MHz	TX power : Low1 Mode : Narrow
8	136.100 MHz	TX power : Low1 Mode : Narrow
9	173.900 MHz	TX power : Low1 Mode : Narrow
10**	155.000 MHz	TX power : Low1 Mode : Middle
11**	136.100 MHz	TX power : Low1 Mode : Middle
12**	173.900 MHz	TX power : Low1 Mode : Middle
13	155.000 MHz	TX power : Low1 Mode : Wide
14	136.100 MHz	TX power : Low1 Mode : Wide
15	173.900 MHz	TX power : Low1 Mode : Wide
16*	155.000 MHz	TX power : Low1 Mode : Digital
17*	136.100 MHz	TX power : Low1 Mode : Digital
18*	173.900 MHz	TX power : Low1 Mode : Digital
19	155.000 MHz	TX power : Low1 Mode : Wide Tone : CTCSS 151.4 Hz
20	136.100 MHz	TX power : Low1 Mode : Wide

*; Necessary only when the optional UT-119H or UT-126H is installed.

**; [F3062], [F3162] only.

• CONNECT

Standard signal generator
0.1 μ V to 32 mV
(-127 dBm to -17 dBm)

CAUTION!
DO NOT transmit while
the SSG is connected to
the antenna connector

Attenuator
20 dB or 30 dB

FM
deviation meter

Oscilloscope

RF power meter
0.1-10 W/50 Ω

Frequency
counter

to the antenna connector

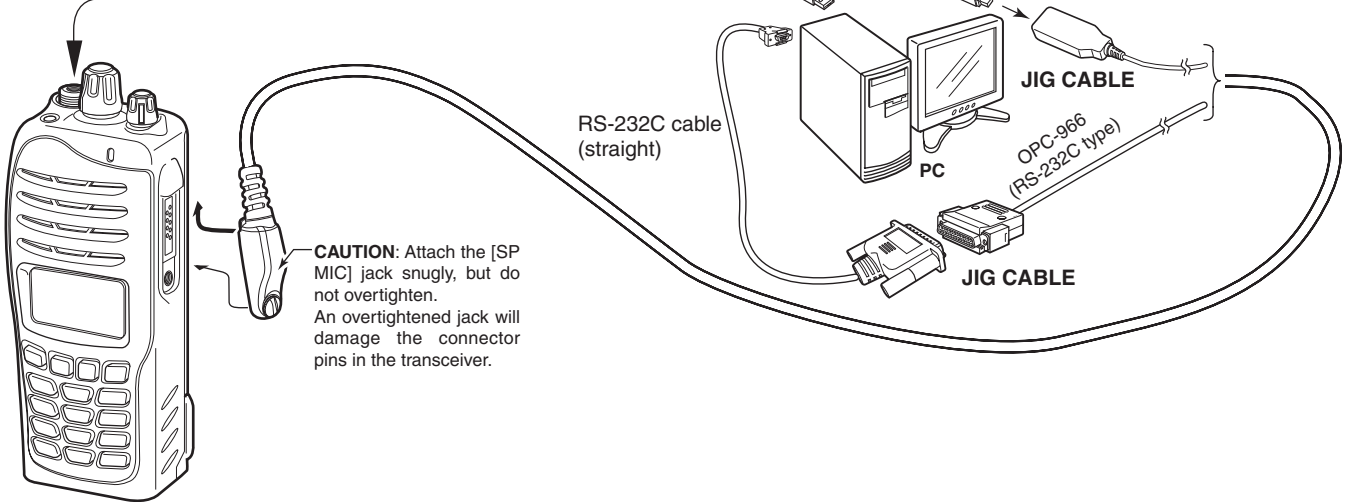

CAUTION: Attach the [SP MIC] jack snugly, but do not overtighten. An overtightened jack will damage the connector pins in the transceiver.

• JIG CABLES

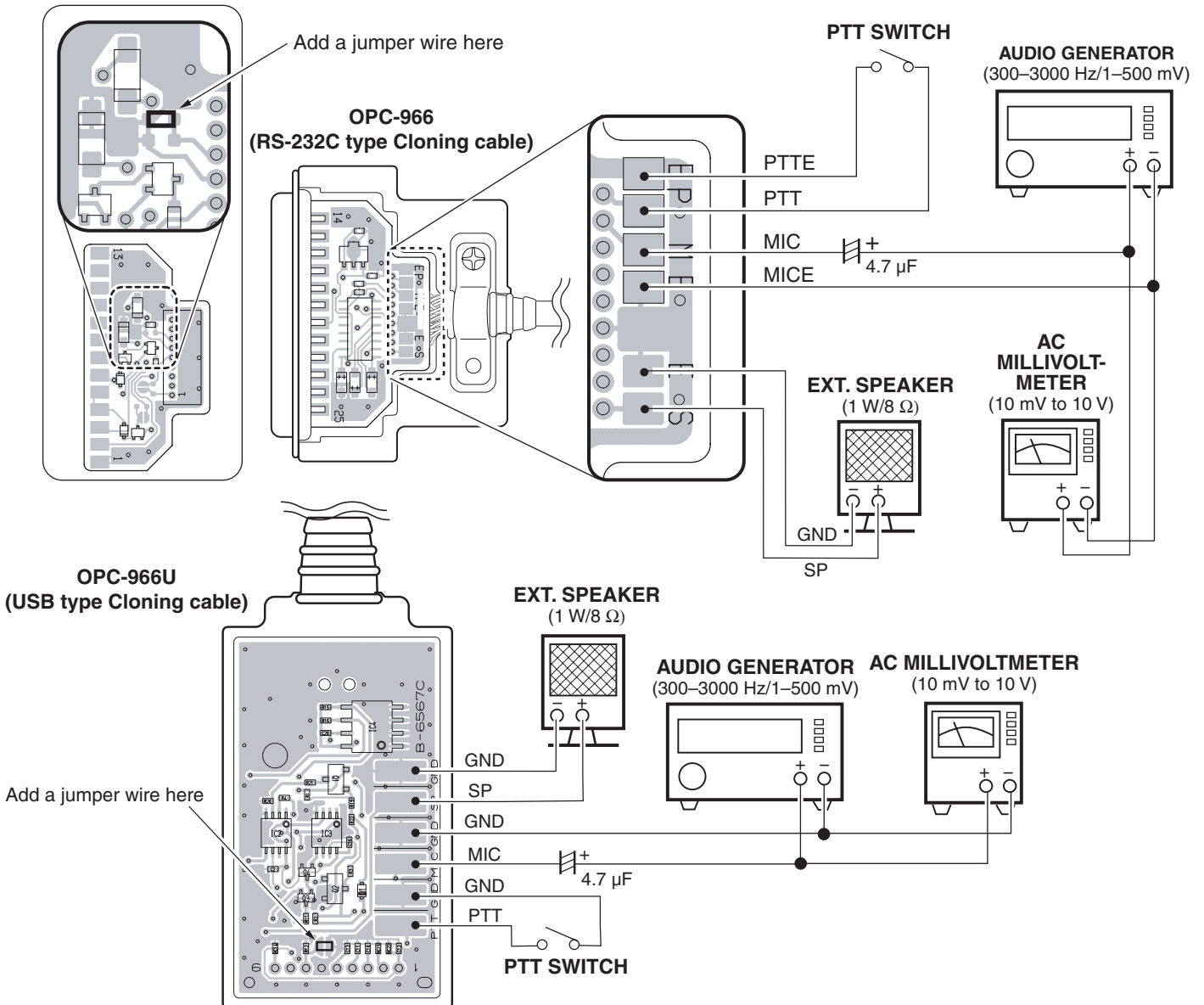

• ADJUSTMENT WINDOW

Adjust Utility

Setting

CH No. 1 RX=0.00000, TX=0.00000
 RF Power=High, Mode=Wide
 CH Type=Analog

Adjust

Power (Hi) 0 [-----]
 Power (L2) 0 [-----]
 Power (L1) 0 [-----]

BAL (Wide) 0 [-----]
 BAL (Mid) 0 [-----]
 BAL (Narrow) 0 [-----]
 BAL (Digital) 0 [-----]

MOD (Wide) 0 [-----]
 MOD (Mid) 0 [-----]
 MOD (Narrow) 0 [-----]
 MOD (Digital) 0 [-----]

CTCSS/DTCS 0 [-----]
 SQL 0 [-----]
 REF 0 [-----]

BPF C ALL [Enter] to Sweep
 BPF T1 C 0 [-----] [Enter] to Sweep
 BPF T2 C 0 [-----] [Enter] to Sweep
 BPF L ALL [Enter] to Sweep
 BPF T1 L 0 [-----] [Enter] to Sweep
 BPF T2 L 0 [-----] [Enter] to Sweep
 BPF H ALL [Enter] to Sweep
 BPF T1 H 0 [-----] [Enter] to Sweep
 BPF T2 H 0 [-----] [Enter] to Sweep

RX LVA1 0 [-----] [Enter] to Sweep
 RX LVA2 0 [-----] [Enter] to Sweep
 TX LVA 0 [-----] [Enter] to Sweep
 LV (RX1) 0 0.00V
 LV (RX2) 0 0.00V
 LV (TX) 0 0.00V

RSSI 0 [Enter] to Capture

MOD N C 0 [Enter] to Capture
 MOD N L 0 [Enter] to Capture
 MOD N H 0 [Enter] to Capture

MOD N H 0 [Enter] to Capture
 MOD M C 0 [Enter] to Capture
 MOD M L 0 [Enter] to Capture
 MOD M H 0 [Enter] to Capture
 MOD W C 0 [Enter] to Capture
 MOD W L 0 [Enter] to Capture
 MOD W H 0 [Enter] to Capture
 MOD D C 0 [Enter] to Capture
 MOD D L 0 [Enter] to Capture
 MOD D H 0 [Enter] to Capture

Digital Mode 1

S.Tone 0 [-----]

*; [F3062], [F3162] only
 **; [F3160] series only

NOTE: The above values for settings are example only.
 Each transceiver has its own specific values for each setting.

6-2 FREQUENCY ADJUSTMENT

Select an adjustment item using [↑]/[↓] keys, then set to the specified value using [←-]/[→-] keys on the connected PC's keyboard.

ADJUSTMENT	ADJUSTMENT CONDITION	MEASUREMENT		VALUE
		UNIT	OPERATION	
PLL LOCK VOLTAGE [RX LVA1]	1 • Channel : CH 1 • Lock voltage preset [LV (RX1)] : 164 [3.2 V] • Receiving	PC screen	Click [I/O Check] in the Clone menu to open the "I/O Check window." Click [Update (F5)] button, then check the "LVIN" item on the adjustment software's screen as below.	3.2 V
[RX LVA2]	2 • Channel : CH 2 • Lock voltage preset [LV (RX2)] : 153 [3.0 V] • Receiving			3.0 V
[TX LVA]	3 • Channel : CH 2 • Lock voltage preset [LV (TX)] : 153 [3.0 V] • Transmitting			
PLL LOCK VOLTAGE	1 • Channel : CH 3 • Receiving	PC screen	Click [Update (F5)] button, then check the "LVIN" item on the adjustment software's screen.	0.6–1.6 V (Verify)
	2 • Channel : CH 4 • Receiving			
	3 • Channel : CH 3 • Transmitting			
REFERENCE FREQUENCY [REF]	• Channel : CH 2 • Connect an RF power meter to the antenna connector. • Transmitting	Top panel	Loosely couple a frequency counter to the antenna connector.	173.90000 MHz

• I/O Check window

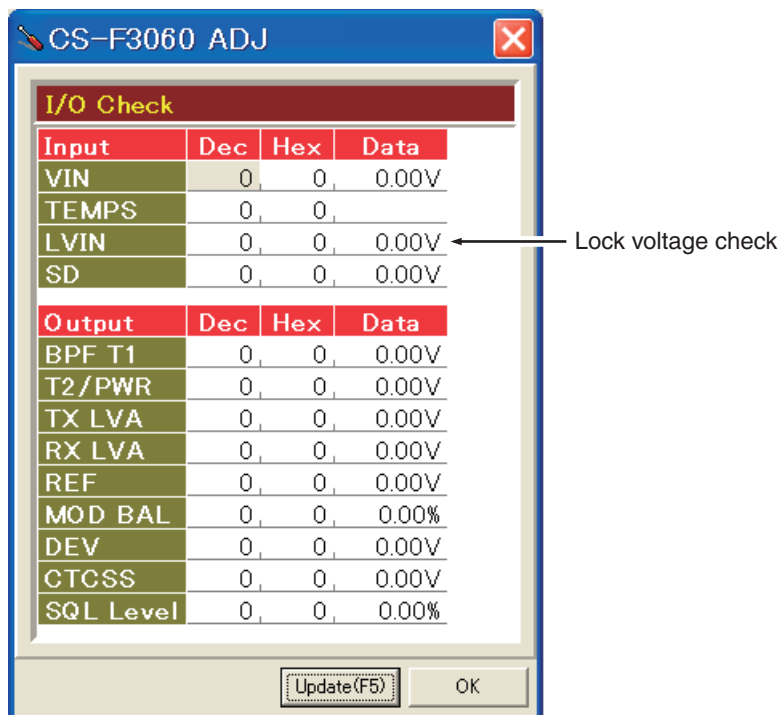

NOTE: The above values are example only.
Each transceiver has its own specific values for each item.

6-3 TRANSMIT ADJUSTMENT

Select an adjustment item using [↑] / [↓] keys, then set to the specified value using [←] / [→] keys on the connected PC's keyboard.

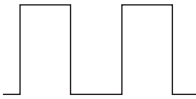
ADJUSTMENT	ADJUSTMENT CONDITION	MEASUREMENT		VALUE
		UNIT	OPERATION	
OUTPUT POWER [Power (Hi)]	1 • Channel : CH 6 • Transmitting	Top panel	Connect an RF power meter to the antenna connector.	5.0 W
[Power (L2)]	2 • Channel : CH 5 • Transmitting			2.0 W
[Power (L1)] (Other than [FRG-01])	3 • Channel : CH 4 • Transmitting			1.0 W
([FRG-01] only)	• Channel : CH 2 • Transmitting			1.15 W
MODULATION BALANCE [BAL (Narrow)]	1 • Channel : CH 4 • Preset [MOD Narrow] : 60 • No audio applied to the JIG cable. • Set an FM deviation meter same as; HPF : OFF LPF : 20 kHz De-emphasis : OFF Detector : (P-P)/2 • Push [P0] key while transmitting.	Top panel	Connect the FM deviation meter to the antenna connector through an attenuator.	Set to square wave form 
FM DEVIATION (NARROW) [MOD N C]	1 • Channel : CH 7 • Connect an audio generator to the JIG cable and set as; Frequency : 1.0 kHz Level : 150 mV rms • Set the FM deviation meter to same condition as "MODULATION BALANCE." • Transmitting	Top panel	Connect the FM deviation meter to the antenna connector through an attenuator.	±2.05 to ±2.15 kHz
(NARROW) [MOD N L]	2 • Channel : CH 8 • Transmitting			
(NARROW) [MOD N H]	3 • Channel : CH 9 • Transmitting			
(WIDE) [MOD W C]	4 • Channel : CH 13 • Transmitting			±4.05 to ±4.15 kHz
(WIDE) [MOD W L]	5 • Channel : CH 14 • Transmitting			
(WIDE) [MOD W H]	6 • Channel : CH 15 • Transmitting			
(MIDDLE)* [MOD M C]	7 • Channel : CH 10 • Transmitting			±3.20 to ±3.30 kHz
(MIDDLE)* [MOD M L]	8 • Channel : CH 11 • Transmitting			
(MIDDLE)* [MOD M H]	9 • Channel : CH 12 • Transmitting			
DIGITAL DEVIATION** [MOD D C]	1 • Preset [Digital Mode] : 7 2 • Channel : CH 16 • Set the FM deviation meter to same condition as "MODULATION BALANCE." • Transmitting	Top panel	Connect an FM deviation meter to the antenna connector through an attenuator.	±1.35 to ±1.39 kHz
[MOD D L]	3 • Channel : CH 17 • Transmitting			
[MOD D H]	4 • Channel : CH 18 • Transmitting			

*; [F3062], [F3162] only. Necessary and sufficient FM DEVIATION adjustment for [FRG-01].

**; Necessary only when the optional UT-119H or UT-126H is installed. Not necessary for [FRG-01].

6-3 TRANSMIT ADJUSTMENT (continued)

Select an adjustment item using [↑] / [↓] keys, then set to the specified value using [←] / [→] keys on the connected PC's keyboard.

ADJUSTMENT	ADJUSTMENT CONDITION	MEASUREMENT		VALUE
		UNIT	OPERATION	
CTCSS/DTCS DEVIATION [CTCSS/DTCS]	1 <ul style="list-style-type: none"> • Channel : CH 19 • No audio applied to the JIG cable. • Set the FM deviation meter to same condition as "MODULATION BALANCE." • Transmitting 	Top panel	Connect an FM deviation meter to the antenna connector through an attenuator.	±0.68 to ±0.72 kHz (Other than [FRG-01]) ±0.53 to ±0.57 kHz ([FRG-01])
2/5 TONE DTMF*** [S.Tone]	1 <ul style="list-style-type: none"> • Channel : CH 7 • Set the FM deviation meter to same condition as "MODULATION BALANCE." • Transmitting 	Top panel	Connect an FM deviation meter to the antenna connector through an attenuator.	±1.50 kHz
	2			

***; [F3160] series only.

6-4 RECEIVE ADJUSTMENT

Select an adjustment item using [↑]/[↓] keys, then set to the specified value using [←-]/[→] keys on the connected PC's keyboard.

ADJUSTMENT	ADJUSTMENT CONDITION	MEASUREMENT		VALUE	
		UNIT	LOCATION		
RECEIVE SENSITIVITY [BPF C ALL]	NOTE: "RECEIVE SENSITIVITY" must be adjusted before "S-METER." Otherwise, "S-METER" will not be adjusted properly.				
	1	<ul style="list-style-type: none"> • Channel : CH 20 • Connect the SSG to the antenna connector and set as; <ul style="list-style-type: none"> Frequency : 136.100 MHz Level : +20 dBμ[†] (-87 dBm) Modulation : 1 kHz Deviation : ±3.5 kHz • Receiving 	Multi connector	Connect the SINAD meter with an 8 Ω load to the JIG cable.	Minimum distortion level
S-METER [RSSI]	1	<ul style="list-style-type: none"> • Channel : CH 20 • Connect the SSG to the antenna connector and set as; <ul style="list-style-type: none"> Frequency : 136.100 MHz Level : +23 dBμ[†] (-84 dBm) Modulation : 1 kHz Deviation : ±3.5 kHz • Receiving 	Push the [ENTER] key on the connected PC's keyboard to set "S3" level.		
	2	<ul style="list-style-type: none"> • Set the SSG as; <ul style="list-style-type: none"> Level : -7dBμ[†] (-114 dBm) • Receiving 	Push the [ENTER] key on the connected PC's keyboard to set "S1" level.		
SQUELCH [SQL]	1	<ul style="list-style-type: none"> • Channel : CH 20 • Close the squelch by adjusting the value of [SQL] item on the adjustment software's screen. • Connect the SSG to the antenna connector and set as; <ul style="list-style-type: none"> Frequency : 136.100 MHz Level : -14 dBμ[†] (-121 dBm) Modulation : 1 kHz Deviation : ±3.5 kHz • Receiving 	External speaker	Connect an 8 Ω speaker to the JIG cable.	Set the [SQL] value to close squelch. Then set [SQL] value at the point where the audio signals just appear.

[†]The output level of the standard signal generator (SSG) is indicated as the SSG's open circuit.

[MAIN-A UNIT] (for F3160 series)

REF NO.	PARTS NO.	DESCRIPTION	M.	H/V LOCATION
EP1	6910015370	S.BEA ACZ1005Y-102-T	B	53.5/22.5
EP3	6910015370	S.BEA ACZ1005Y-102-T	B	45.5/36.8
EP4	6910015600	S.BEA ACZ1005Y-241 (240)	B	56.4/39.6
EP5	6910015370	S.BEA ACZ1005Y-102-T	B	62.6/21.7
EP7	0880002600	UBD EX-2887 [F3062S EUR-01], [F3160DT/DS]		

[RF UNIT]

REF NO.	PARTS NO.	DESCRIPTION	M.	H/V LOCATION
IC601	1110002750	S.IC TA75S01F (TE85R) Except [FRG-01]	T	24.4/23.1
	1110002751	S.IC TA75S01F (TE85R,F) [FRG-01]	T	24.4/23.1
Q601	1560001230	S.FET RD07MVS1 [F3061T], [F3063T], [F3061S], [F3063S]	B	8/6.5
	1560001231	S.FET RD07MVS1-T112 [F3062T], [F3062S EUR-01], [FRG-01]	B	8/6.5
Q602	1560001241	S.FET RD01MUS1-T113	B	3.5/13.2
Q603	1530003420	S.TR 2SC5110-O (TE85R) [F3061T], [F3063T], [F3061S], [F3063S]	B	8/18.1
	1530003421	S.TR 2SC5110-O (TE85R,F) [F3062T], [F3062S EUR-01], [FRG-01]	B	8/18.1
Q604	1590002160	S.TR XP6401-(TX)	T	7.7/15.3
Q605	1530002060	S.TR 2SC4081 T106 R	T	8/17.9
Q606	1590003290	S.TR UNR9213J-(TX)	T	21/20.5
D601	1750000580	S.DIO 1SV307 (TPH3) [F3061T], [F3063T], [F3061S], [F3063S]	T	22.4/10
	1750000581	S.DIO 1SV307 (TPH3,F) [F3062T], [F3062S EUR-01], [FRG-01]	T	22.4/10
D603	1750000580	S.DIO 1SV307 (TPH3) [F3061T], [F3063T], [F3061S], [F3063S]	B	17.8/13.2
	1750000581	S.DIO 1SV307 (TPH3,F) [F3062T], [F3062S EUR-01], [FRG-01]	B	17.8/13.2
D604	1790001670	S.DIO RB706F-40T106	T	17.4/6.1
D605	1790001670	S.DIO RB706F-40T106	B	28.4/21.7
D606	1790001250	S.DIO MA2S111-(TX)	T	29.8/21.7
D607	1730002430	S.ZEN MA8150-M (TX) [F3062T], [F3060S]	T	17.2/21.4
L601	6200008580	S.COL 0.30-1.4-6TL 32N Except [FRG-01]	B	30.8/9.2
	6200012780	S.COL 0.30-1.4-6TL 27.2N [FRG-01]	B	30.8/9.2
L602	6200008280	S.COL 0.30-1.7-7TL 50N Except [FRG-01]	B	30.2/12.4
L602	6200012470	S.COL 0.30-1.7-7TL 45.3N [FRG-01]	B	30.2/12.4
L603	6200008170	S.COL 0.35-1.6-8TL 54N Except [FRG-01]	B	27.3/15.7
	6200012910	S.COL 0.35-1.6-8TL 45.5N [FRG-01]	B	27.3/15.7
L604	6200008280	S.COL 0.30-1.7-7TL 50N Except [FRG-01]	B	20.1/13.1
L605	6200012470	S.COL 0.30-1.7-7TL 45.3N [FRG-01]	B	20.1/13.1
L606	6200002861	S.COL NLV25T-4R7J	T	25.2/11.1
L606	6200008580	S.COL 0.30-1.4-6TL 32N Except [FRG-01]	B	20.5/4.4
	6200012780	S.COL 0.30-1.4-6TL 27.2N [FRG-01]	B	20.5/4.4
L607	6200008490	S.COL 0.30-0.9-3TR 7.5N Except [FRG-01]	B	16/4.1
L608	6200012390	S.COL 0.30-0.92-3TR 5.8N [FRG-01]	B	16/4.1
	6200009710	S.COL 0.30-0.9-4TL 10.5N Except [FRG-01]	B	12.6/5.6
L609	6200012400	S.COL 0.30-0.91-4TL 8.6N [FRG-01]	B	12.6/5.6
	6200008330	S.COL 0.45-1.4-4TL 15N Except [FRG-01]	B	9.2/11.8
L610	6200012960	S.COL 0.45-1.4-4TL 12.1N [FRG-01]	B	9.2/11.8
L611	6200005711	S.COL ELJRE 27NGFA	B	6.7/13.8
L612	6200003590	S.COL EXCCL3225U1	B	14.6/17.4
L612	6200005731	S.COL ELJRE 39NGFA	B	4.6/18.6
L613	6200006190	S.COL BLM21PG300SN1D	T	13.1/20.2
R601	7030003680	S.RES ERJ3GEYJ 104 V (100 k)	T	29/8.3
R603	7030009140	S.RES ERJ2GEJ 272 X (2.7 k)	B	18/3.3
R604	7030005040	S.RES ERJ2GEJ 472 X (4.7 k)	T	17.7/9
R605	7030005040	S.RES ERJ2GEJ 472 X (4.7 k)	T	17.7/10
R606	7030005050	S.RES ERJ2GEJ 103 X (10 k)	T	27.6/20.4
R607	7030005090	S.RES ERJ2GEJ 104 X (100 k)	T	19.4/20.9
R608	7030005110	S.RES ERJ2GEJ 224 X (220 k)	T	26.6/22
R609	7030005530	S.RES ERJ2GEJ 100 X (10)	B	24.1/24.7
R610	7030007290	S.RES ERJ2GEJ 222 X (2.2 k)	T	28.6/22
R611	7030004990	S.RES ERJ2GEJ 221 X (220)	T	29.4/20
R613	7030005090	S.RES ERJ2GEJ 104 X (100 k)	B	4.2/7.4
R614	7030005040	S.RES ERJ2GEJ 472 X (4.7 k)	B	2.4/8.6
R615	7030007250	S.RES ERJ2GEJ 220 X (22)	B	4/8.6
R616	7030005060	S.RES ERJ2GEJ 333 X (33 k)	B	3.4/17.4
R617	7030005040	S.RES ERJ2GEJ 472 X (4.7 k)	B	2.4/18.4
R618	7030004980	S.RES ERJ2GEJ 101 X (100)	B	3.8/16.2
R619	7030004980	S.RES ERJ2GEJ 101 X (100)	B	6/17.7
R620	7030007290	S.RES ERJ2GEJ 222 X (2.2 k)	B	7.7/21.2
R621	7030007290	S.RES ERJ2GEJ 222 X (2.2 k)	B	6.7/20
R622	7030005530	S.RES ERJ2GEJ 100 X (10)	T	6.8/21.4
R623	7030007330	S.RES ERJ1WRSJR15U (0.15)	T	16/16.8
R624	7030005120	S.RES ERJ2GEJ 102 X (1 k)	T	12.9/14.4
R625	7030005050	S.RES ERJ2GEJ 103 X (10 k)	T	6/18.1
R626	7030005120	S.RES ERJ2GEJ 102 X (1 k)	T	7.7/20.2
R627	7030005060	S.RES ERJ2GEJ 333 X (33 k)	T	6.7/20.2
R628	7030003370	S.RES ERJ3GEYJ 271 V (270)	T	26.7/17
R629	7030003370	S.RES ERJ3GEYJ 271 V (270)	T	25.4/17
R631	7030008300	S.RES ERJ2GEJ 184 X (180 k)	T	21.7/18.7
R632	7030009140	S.RES ERJ2GEJ 272 X (2.7 k)	B	28.7/19.2
R633	7030005040	S.RES ERJ2GEJ 472 X (4.7 k) [F3061T], [F3063T]	B	26.5/20.8
	7030007340	S.RES ERJ2GEJ 153 X (15 k) [F3062T], [F3060S]	B	26.5/20.8
C601	4030006990	S.CER C1608 CH 1H 080D-T	B	30.6/6.4
C602	4030011770	S.CER C1608 CH 1H 060B-T	B	33.1/10.5
C604	4030009650	S.CER C1608 CH 1H 240J-T	B	28.5/7.7
C605	4030009920	S.CER C1608 CH 1H 050B-T	B	32.3/13.1

M.=Mounted side (T: Mounted on the Top side, B: Mounted on the Bottom side) S.=Surface mount

[RF UNIT]

REF NO.	PARTS NO.	DESCRIPTION	M.	H/V LOCATION
C606	4030007060	S.CER C1608 CH 1H 270J-T	B	28.1/11.7
C608	4030009540	S.CER C1608 CH 1H 1R5B-T	B	27.7/17.8
C609	4030007020	S.CER C1608 CH 1H 120J-T	B	25.5/11.7
C610	4030017460	S.CER ECJ0EB1E102K	B	24.1/12.1
C611	4030007020	S.CER C1608 CH 1H 120J-T	B	23.4/10.3
C612	4030017650	S.CER ECJ0EC1H270J	B	21.1/15.5
C613	4030017460	S.CER ECJ0EB1E102K	T	25.8/13.3
C614	4030017460	S.CER ECJ0EB1E102K	T	25.3/19.2
C615	4030017460	S.CER ECJ0EB1E102K	T	21.7/8
C616	4030007040	S.CER C1608 CH 1H 180J-T	B	20.9/8
C617	4030007040	S.CER C1608 CH 1H 180J-T	B	19.6/8
C618	4030017530	S.CER ECJ0EC1H0R5B	T	17.4/3.8
C619	4030017460	S.CER ECJ0EB1E102K	T	17.7/8
C620	4030017460	S.CER ECJ0EB1E102K	B	19.3/6.3
C622	4030011770	S.CER C1608 CH 1H 060B-T	B	18.3/8
C623	4030007100	S.CER C1608 CH 1H 560J-T	B	17.9/5.4
C624	4030007110	S.CER C1608 CH 1H 680J-T	B	14.5/6.5
C626	4030017460	S.CER ECJ0EB1E102K	T	28.2/17.5
C627	4030016790	S.CER ECJ0EB1C103K	T	21.8/22.3
C628	4030016790	S.CER ECJ0EB1C103K	T	27.6/22
	4030016930	S.CER ECJ0EB1A104K		
		[F3061T], [F3063T], [F3061S], [F3063S]	T	27.6/22
	4030016940	S.CER ECJ0EB1A393K		
		[F3062T], [F3062S EUR-01], [FRG-01]	T	27.6/22
C629	4030017460	S.CER ECJ0EB1E102K	B	25.8/18.8
C630	4030016930	S.CER ECJ0EB1A104K	T	24.5/25.3
C631	4030017460	S.CER ECJ0EB1E102K	T	28.6/18.7
C632	4030017460	S.CER ECJ0EB1E102K	B	21/20.2
C633	4030017460	S.CER ECJ0EB1E102K	B	13.7/15.4
C634	4030017460	S.CER ECJ0EB1E102K	B	2.2/7.4
C635	4030017730	S.CER ECJ0EB1E471K	B	3.2/7.4
C637	4030017460	S.CER ECJ0EB1E102K	T	3.1/9.3
C638	4030017430	S.CER ECJ0EC1H101J	B	4.7/9.8
C639	4030017490	S.CER C1608 JB 1A 105K-T	B	13.8/14.2
C640	4030017460	S.CER ECJ0EB1E102K	B	8.1/14.7
C642	4030016790	S.CER ECJ0EB1C103K	B	2.2/16.2
C643	4030017460	S.CER ECJ0EB1E102K	B	2.2/17.2
C644	4030017420	S.CER ECJ0EC1H470J	T	2/18.8
C645	4030017460	S.CER ECJ0EB1E102K	T	4.2/18.8
C646	4030017430	S.CER ECJ0EC1H101J	B	5/16.5
C647	4030017420	S.CER ECJ0EC1H470J	T	5.6/21.5
C648	4030017460	S.CER ECJ0EB1E102K	B	5.7/21.5
C649	4030017460	S.CER ECJ0EB1E102K	T	10.1/22.8
C650	4030017460	S.CER ECJ0EB1E102K	B	6/18.7
C651	4030017650	S.CER ECJ0EC1H270J	B	8.3/20
C653	4030017460	S.CER ECJ0EB1E102K	T	17.2/14.2
C654	4030017460	S.CER ECJ0EB1E102K	T	6/17.1
C655	4030017460	S.CER ECJ0EB1E102K	T	8.7/20.2
C656	4030016930	S.CER ECJ0EB1A104K	T	16.5/19.4
C657	4030017460	S.CER ECJ0EB1E102K	T	15.5/19.4
C658	4030017420	S.CER ECJ0EC1H470J	T	14.5/19.4
C659	4030017420	S.CER ECJ0EC1H470J	T	14.7/21.2
C660	4030017460	S.CER ECJ0EB1E102K	T	13.2/23.8
C661	4030016930	S.CER ECJ0EB1A104K	T	12.2/23.8
C662	4030017460	S.CER ECJ0EB1E102K	B	6.8/11.2
C663	4030009920	S.CER C1608 CH 1H 050B-T	B	34.3/10.5
C664	4030011770	S.CER C1608 CH 1H 060B-T	B	15.7/6.5
C665	4030017530	S.CER ECJ0EC1H0R5B	B	29.8/20.1
C666	4030017460	S.CER ECJ0EB1E102K	B	26.5/22.4
C667	4030018910	S.CER C1608 JB 0J 475K-T		
		[F3062T], [F3062S EUR-01], [FRG-01] only	B	23.5/22.3
J601	6910017940	CNR IMSA-9230B-1-05Z118-PT1		
J602	6910017940	CNR IMSA-9230B-1-05Z118-PT1		
F601	5210000970	S.FUS ERBSE3R00U	T	13.9/22.4
EP602	6910012350	S.BEA MMZ1608Y 102BT	B	7.8/15.8

[JACK UNIT]

REF NO.	PARTS NO.	DESCRIPTION	M.	H/V LOCATION
D801	1790001810	S.VSR AVR-M1005C080MTABB	B	13.7/1.7
D802	1790001810	S.VSR AVR-M1005C080MTABB	B	14.7/3.8
D803	1790001810	S.VSR AVR-M1005C080MTABB	B	13.8/3.8
D804	1790001810	S.VSR AVR-M1005C080MTABB	B	14.1/2.6
D805	1790001810	S.VSR AVR-M1005C080MTABB	B	13.5/0.8
J801	6510025140	S.CNR 10FLT-SM1-TB Except [FRG-01]	B	5/2.6
	6510025141	S.CNR 10FLT-SM2-TB (LF) [FRG-01]	B	5/2.6
EP801	6910012350	S.BEA MMZ1608Y 102BT	B	10/3.7
EP802	6910012350	S.BEA MMZ1608Y 102BT	B	10/2.2
EP803	6910012350	S.BEA MMZ1608Y 102BT	B	10/9

[VR UNIT] (for other than [FRG-01])

REF NO.	PARTS NO.	DESCRIPTION	M.	H/V LOCATION
Q701	1590001400	S.TR XP1214 (TX)	T	32.2/6.2
R701	7410001140	S.ARY EXB28V104JX	T	11.4/1.8
R702	7030007280	S.RES ERJ2GEJ 331 X (330)	T	31.7/8.6
R703	7030005030	S.RES ERJ2GEJ 152 X (1.5 k)	T	32.7/8.6
R704	7210003061	VAR TP76N00N-15F-A103-2251A		
R705	7030005090	S.RES ERJ2GEJ 104 X (100 k)	T	13.2/2.8
C701	4030017420	S.CER ECJ0EC1H470J	T	10.1/5.2
C702	4030017420	S.CER ECJ0EC1H470J	T	11.1/5.2
C703	4030017420	S.CER ECJ0EC1H470J	T	12.1/5.2
C704	4030017420	S.CER ECJ0EC1H470J	T	14.3/3.2
J701	6510024930	S.CNR 20RF-JMCSG1BTF (N) (LF)(SN)	B	11.4/4.1
DS701	5040002670	S.LED CL-165HR/YG	T	33.5/11.1
S701	2250000490	ECR TP70TF5163-15.9F-2775		
S702	2230001060	S.SW EVQ-PUL 02K	T	8/10.4

[VR-A UNIT] (for [FRG-01])

REF NO.	PARTS NO.	DESCRIPTION	M.	H/V LOCATION
Q701	1590001400	S.TR XP1214 (TX)	T	32.2/6.2
R701	7410001140	S.ARY EXB28V104JX	T	11.2/1.8
R702	7030007280	S.RES ERJ2GEJ 331 X (330)	T	31.7/8.6
R703	7030005030	S.RES ERJ2GEJ 152 X (1.5 k)	T	32.7/8.6
R704	7210003061	VAR TP76N00N-15F-A103-2251A		
R705	7030005090	S.RES ERJ2GEJ 104 X (100 k)	T	13.1/2.9
C701	4030017420	S.CER ECJ0EC1H470J	T	10.1/5.2
C702	4030017420	S.CER ECJ0EC1H470J	T	11.1/5.2
C703	4030017420	S.CER ECJ0EC1H470J	T	12.1/5.2
C704	4030017420	S.CER ECJ0EC1H470J	T	14/3.9
J701	6510024930	S.CNR 20RF-JMCSG1BTF (N) (LF)(SN)	B	11.4/4.1
DS701	5040002670	S.LED CL-165HR/YG	T	33.5/11.1
S701	2250000600	ECR TP70N1035E20-15.9F-2893		
S702	2230001060	S.SW EVQ-PUL 02K	T	8/10.4

M.=Mounted side (T: Mounted on the Top side, B: Mounted on the Bottom side)
S.=Surface mount

• BC-160 (Optional)

[MAIN UNIT]

REF NO.	ORDER NO.	DESCRIPTION	M.	H/V LOCATION
IC1	1110006480	S.IC NJM2801U1-0543-TE1	B	10.2/62.3
IC2	1110003071	S.IC uPC494GS-E1-A	B	13/36.7
IC3	1140012301	S.IC uPD789112AMC-534-5A4-A	B	19.1/19.6
IC4	1110002700	S.IC NJM2904M-TE1	B	35.1/13.8
Q1	1530002060	S.TR 2SC4081 T106 R	B	37.3/63.9
Q2	1550000090	S.FET RSOQ035P03TR	B	37.3/60.9
Q3	1530002060	S.TR 2SC4081 T106 R	B	35.8/19.3
Q4	1530002060	S.TR 2SC4081 T106 R	B	41.6/18.3
Q5	1590000430	S.TR DTC144EUA T106	B	23.7/26.6
Q6	1530002060	S.TR 2SC4081 T106 R	B	22.5/58.2
D1	1730002350	S.ZEN MA8110-M (TX)	B	17.6/60.5
D2	1750000550	S.DIO 1SS355 TE-17	B	34.8/64.4
D3	1750001110	S.DIO SM240A-T	B	44.4/56
D4	1160000070	S.DIO DAN202K T146	B	26.9/20.6
D5	1750000550	S.DIO 1SS355 TE-17	B	27.2/15
X1	6060000790	S.CER CSTCR4M91G	B	10.3/17.7
L1	6190001640	S.COL SLF12555T-101M1R1	B	35.3/52.7
L2	6200002611	S.COL NLV25T-R47J	B	20.8/28.2
R2	7030000460	S.RES MCR10EZHZJ 4.7 k	B	20.3/58.6
R3	7030003410	S.RES ERJ3GEYJ 561 V (560)	B	37.3/65.8
R4	7030003200	S.RES ERJ3GEYJ 100 V (10)	B	34.6/61.1
R5	7030009580	S.RES ERJ8RSJ R12V	B	31.8/73
R6	7030000540	S.RES MCR10EZHZJ 22 k	B	30.1/26.8
R7	7030000380	S.RES MCR10EZHZJ 1 k	B	30.1/29.6
R8	7030003520	S.RES ERJ3GEYJ 472 V (4.7 k)	B	39.5/18.4
R9	7030003600	S.RES ERJ3GEYJ 223 V (22 k)	B	13.8/30.5
R10	7030000740	S.RES MCR10EZHZJ 1 M	B	25.8/34.9
R11	7030000540	S.RES MCR10EZHZJ 22 k	B	24.8/37.8
R12	7030003560	S.RES ERJ3GEYJ 103 V (10 k)	B	10.8/30.5
R13	7030003600	S.RES ERJ3GEYJ 223 V (22 k)	B	19.3/34.5
R14	7030003770	S.RES ERJ3GEYJ 564 V (560 k)	B	21/34.5
R15	7030003650	S.RES ERJ3GEYJ 563 V (56 k)	B	21/40.3
R16	7030003770	S.RES ERJ3GEYJ 564 V (560 k)	B	19.3/40.3
R17	7030003560	S.RES ERJ3GEYJ 103 V (10 k)	B	22.7/40.3
R18	7030003410	S.RES ERJ3GEYJ 561 V (560)	B	8.6/43.5
R19	7030003620	S.RES ERJ3GEYJ 333 V (33 k)	B	16.7/42.1
R20	7030000560	S.RES MCR10EZHZJ 33 k	B	28.1/40.4
R21	7030000380	S.RES MCR10EZHZJ 1 k	B	26.3/28.6
R22	7030000440	S.RES MCR10EZHZJ 3.3 k	B	24/11.4
R23	7030000460	S.RES MCR10EZHZJ 4.7 k	B	24/8.8
R24	7030000260	S.RES MCR10EZHZJ 100 (101)	B	20.3/11.4
R25	7030000260	S.RES MCR10EZHZJ 100 (101)	B	20.3/8.8
R26	7030000500	S.RES MCR10EZHZJ 10 k	B	30.5/22
R27	7030007220	S.RES ERA3YED 202V (2 k)	B	30.2/19.6
R28	7030011200	S.RES ERA3YEB 303V (30 k)	B	30/18.1
R29	7030011190	S.RES ERA3YEB 103V (10 k)	B	26.9/16.6
R30	7030005871	S.RES ERA3YKD 104V (100 k)	B	40.4/15.1
R31	7030003560	S.RES ERJ3GEYJ 103 V (10 k)	B	29.8/15.9
R32	7030005341	S.RES ERA3YED 332V (3.3 k)	B	43.4/11.1
R33	7030000500	S.RES MCR10EZHZJ 10 k	B	31.7/9.8
R34	7030000740	S.RES MCR10EZHZJ 1 M	B	42.1/14.4
R35	7030003440	S.RES ERJ3GEYJ 102 V (1 k)	B	40.4/12.2
R36	7030000460	S.RES MCR10EZHZJ 4.7 k	B	34.7/23.8
R37	7030005501	S.RES ERA3YKD 124V (120 k)	B	33.6/21.3
R38	7030005671	S.RES ERA3YKD 393V (39 k)	B	30.1/25.1
R39	7030000010	S.RES MCR10EZHZJ JPW	B	28.1/42.2
R40	7030000010	S.RES MCR10EZHZJ JPW	B	27.7/8.4
R41	7030000010	S.RES MCR10EZHZJ JPW	B	34.6/9.2
R42	7030008240	S.RES ERJ12YJ0R00U	B	38.9/7.4
R43	7030000010	S.RES MCR10EZHZJ JPW	B	30.1/33.3
R44	7030000010	S.RES MCR10EZHZJ JPW	B	28.1/33.3
R45	7030000010	S.RES MCR10EZHZJ JPW	B	29.1/38
R46	7030000010	S.RES MCR10EZHZJ JPW	B	29.1/36.1
R47	7030000010	S.RES MCR10EZHZJ JPW	B	43.9/18.3
R48	7030008240	S.RES ERJ12YJ0R00U	B	43/28.9
R49	7030000010	S.RES MCR10EZHZJ JPW	B	23.5/5.7
R50	7030008240	S.RES ERJ12YJ0R00U	B	34.1/38.2
R51	7030000010	S.RES MCR10EZHZJ JPW	B	23.9/34.9
R52	7030000010	S.RES MCR10EZHZJ JPW	B	24.7/32
R53	7030008240	S.RES ERJ12YJ0R00U	B	38.6/33.1
R54	7030000010	S.RES MCR10EZHZJ JPW	B	34.4/33
R55	7030000010	S.RES MCR10EZHZJ JPW	B	32/60.1
R56	7030000010	S.RES MCR10EZHZJ JPW	B	42.1/41.5
R57	7030000010	S.RES MCR10EZHZJ JPW	B	37.2/41.5
R58	7030000010	S.RES MCR10EZHZJ JPW	B	24.9/57
R59	7030000010	S.RES MCR10EZHZJ JPW	B	27.6/49.3
R60	7030000010	S.RES MCR10EZHZJ JPW	B	16.3/58.3
R61	7030000010	S.RES MCR10EZHZJ JPW	B	4.9/31.7
R62	7030000010	S.RES MCR10EZHZJ JPW	B	39.1/41.5
R63	7030000010	S.RES MCR10EZHZJ JPW	B	31.4/43.6
R64	7030000010	S.RES MCR10EZHZJ JPW	B	40.1/38.7
R65	7030000010	S.RES MCR10EZHZJ JPW	B	4.9/49.5
R66	7030003560	S.RES ERJ3GEYJ 103 V (10 k)	B	8.2/13.6
R67	7030000100	S.RES MCR10EZHZJ 4R7 (4.7)	B	10.2/45.1
C1	4030006900	S.CER C1608 JB 1H 103K-T	B	44.5/70.7
C2	4030006900	S.CER C1608 JB 1H 103K-T	B	48.2/73.5
C3	4030006860	S.CER C1608 JB 1H 102K-T	B	44.5/67.8

[MAIN UNIT]

REF NO.	ORDER NO.	DESCRIPTION	M.	H/V LOCATION
C4	4030006900	S.CER C1608 JB 1H 103K-T	B	32.9/69.7
C5	4030006900	S.CER C1608 JB 1H 103K-T	B	32.9/71.1
C6	4510008540	S.ELE EEE1CA100SR	B	17.5/63.8
C7	4030011600	S.CER C1608 JB 1E 104K-T	B	13.4/60.8
C8	4030006900	S.CER C1608 JB 1H 103K-T	B	9.2/58.7
C9	4030011600	S.CER C1608 JB 1E 104K-T	B	13.4/63.8
C10	4510009150	S.ELE EEE1EA470WP	B	43.6/62.8
C11	4030006900	S.CER C1608 JB 1H 103K-T	B	35.8/67.9
C12	4030006900	S.CER C1608 JB 1H 103K-T	B	32.4/67.9
C13	4510009150	S.ELE EEE1EA470WP	B	26.5/62.8
C14	4510008660	S.ELE EEE0JA220SR	B	34.3/28
C15	4510008660	S.ELE EEE0JA220SR	B	40.8/23.8
C16	4030006860	S.CER C1608 JB 1H 102K-T	B	12.3/30.5
C17	4030011600	S.CER C1608 JB 1E 104K-T	B	19.3/37.4
C18	4030006900	S.CER C1608 JB 1H 103K-T	B	21/37.4
C19	4030006900	S.CER C1608 JB 1H 103K-T	B	13.1/42.2
C20	4030009980	S.CER C1608 JB 1H 152K-T	B	8.6/42.1
C21	4030011600	S.CER C1608 JB 1E 104K-T	B	9.5/21.9
C22	4030006900	S.CER C1608 JB 1H 103K-T	B	19/25.5
C23	4030006900	S.CER C1608 JB 1H 103K-T	B	26.9/23.2
C24	4030006900	S.CER C1608 JB 1H 103K-T	B	26.9/18
C25	4030004760	S.CER C2012 JF 1H 104Z-T	B	33.2/17.5
C26	4030006900	S.CER C1608 JB 1H 103K-T	B	41.9/11.1
C27	4030006900	S.CER C1608 JB 1H 103K-T	B	29.5/12.6
C28	4030006900	S.CER C1608 JB 1H 103K-T	B	30.1/23.7
J1	6510024940	CNR HEC2305-016250		
DS1	5040002740	LED RT3-03HRYG		

M.=Mounted side (T: Mounted on the Top side, B: Mounted on the Bottom side)
S.=Surface mount

SECTION 8

MECHANICAL PARTS

[CHASSIS PARTS]

REF. NO.	PARTS NO.	DESCRIPTION	QTY.
J1	6910015910	ANT CONNECTOR 104	1
J2	6910015860	IMSA-6277S-O2A-G	1
SP1	2510001360	K036NAX040A00-55	1
W1	8900014981	OPC-1589-1	1
W2	8900014971	OPC-1590-1	1
MP1	8010020290	2893 CHASSIS	1
MP2	8210022601	2893 T-FRONT PANEL	1
		(Incl. MP5, 6, 13, 25, 27, 28) [10-key]	1
	8210022941	2893 S-FRONT PANEL	1
		(Incl. MP5, 6, 13, 25, 27, 28) [4-key]	1
	8210024050	2893 S-FRONT PANEL (A)	1
		(Incl. MP5, 6, 13, 25, 27, 28) [FRG-01]	1
MP3	8210022540	2893 REAR PANEL	1
MP4	8310065610	2893 WINDOW PLATE	1
MP5	8210022560	2893 PTT PANEL	1
		Except [FRG-01]	1
	8210023970	2893 PTT PANEL (A)	1
		[FRG-01]	1
MP6	8930068630	2893 PTT BUTTON	1
MP7	8930068640	2893 LENS	1
MP8	8610012920	2893 RELEASE PLATE (A)	1
MP9	8610007920	2893 KNOB N-345 (Incl. MP9)	1
MP10	8610012930	2893 KNOB SPRING NO.1500	1
MP11	8610012930	2893 KNOB N-346 (Incl. MP11)	1
MP12	8610007510	2893 KNOB SPRING NO.7800	1
	8930068610	2893 KEYBOARD	1
		[10-key]	1
	8930068960	2893 4-KEY	1
		[4-key]	1
	8930072880	2893 4-KEY (A)	1
		[FRG-01]	1
MP13	8930068620	2893 PTT RUBBER	1
MP14	8930068650	2893 MAIN SEAL	1
MP15	8930068660	2893 WASHER PLATE	1
MP16	8510017650	2893 SHIELD PLATE	1
MP17	8930063060	2721 T-RUBBER	1
MP18	8930070362	2775 RELEASE PLATE (A)-2	1
MP19	8930059360	2600 RELEASE BUTTON	1
MP20	8930056540	PUSH SPRING (AH)	2
MP22	8930058720	2600 9-PIN SHEET	1
MP23	8930055890	2403 CONNECTOR SHEET	1
MP24	8930055730	2403 CONNECTOR SEAL	1
MP25	8830001591	1362 INSERT NUT (A)-1	1
MP26	8930046020	1123 SHEET (A)-1	1
MP27	8930040390	SPEAKER NET (B)	1
MP28	8930046050	SPEAKER NET (C)	1
MP29	8930063411	2775 B-TOP PLATE-1	1
MP30	8830001701	VR NUT (Q)-1	2
MP31	8830001720	2721 ANT NUT	1
MP32	8930048840	2135 MIC SPONGE	1
MP33	8810008641	0TAP 1FLAT WASHER B0 2X4 NI-ZC3 (BT)	6
MP34	8810008971	0TAP 1FLAT WASHER B0 2X3.5NI-ZC3 (BT)	8
MP35	8810009511	SCREW BT B0 2X4 NI-ZC3 (BT)	4
MP36	8810010430	SCREW TRUSS M3X5 SUS SSBC	1
MP38	8810009561	SCREW BT B0 2X6 NI-ZK3 (BT)	2
MP39	8810009221	SCREW BT B0 2X8 NI-ZK3 (BT)	2
MP40	8930069710	THERMALLY SHEET (BC)	1
MP41	8930069860	2893 WINDOW SHEET	1
MP42	8510017710	2893 EARTH PLATE	1
MP44	8930070010	2893 VOL RUBBER	1

[FRONT UNIT] (for F3060 series)

REF. NO.	PARTS NO.	DESCRIPTION	QTY.
J501	6510025240	IMSA-9631S-20A-TB	1
J502	6510025250	IMSA-9631S-08A-TB	1
J503	6510025260	IMSA-9631S-10A-TB	1
DS510	5030002830	M4-0078TAY-2	1
MC501	7700002760	EM6027P-46C33-G-01	1
W501	9028930010	23/04/020/W02/W02	1
W502	9014506004	23/00/025/W02/W02	1
MP501	8210021460	2803 REFLECTOR	1
MP502	8950004430	DOUBLESIDED TAPE (O)	2
MP503	8930062540	SPONGE (HO)	2
MP505*	6910014760	OG-503040	1
MP506	8930069990	SPONGE (IZ)	1
MP507	8930074230	2893 LCD SHEET	1

[FRONT-A UNIT] (for F3160 series)

REF. NO.	PARTS NO.	DESCRIPTION	QTY.
J501*	6510025240	IMSA-9631S-20A-TB	1
J502*	6510025250	IMSA-9631S-08A-TB	1
J503*	6510025260	IMSA-9631S-10A-TB	1
DS510	5030002830	M4-0078TAY-2	1
MC501	7700002760	EM6027P-46C33-G-01	1
W501	9028930010	23/04/020/W02/W02	1
W502	9014506004	23/00/025/W02/W02	1
MP501	8210021460	2803 REFLECTOR	1
MP502	8950004430	DOUBLESIDED TAPE (O)	2
MP503	8930062540	SPONGE (HO)	2
MP505*	6910014760	OG-503040	1
MP506	8930069990	SPONGE (IZ)	1
MP507	8930074230	2893 LCD SHEET	1

[JACK UNIT]

REF. NO.	PARTS NO.	DESCRIPTION	QTY.
J801*	6510025141	10FLT-SM2-TB (LF) (SN)	1
MP801*	8950005520	2403 9-PIN CONNECTOR	1
MP802	8930069960	2893 EARTH SPRING	1

[MAIN UNIT] (for F3060 series)

REF. NO.	PARTS NO.	DESCRIPTION	QTY.
J1*	6510025220	AXK540145J	1
J2*	6510025220	AXK540145J	1
J3*	6510025190	IMSA-9639S-20Y905	1
J4*	6510023970	20P3.5-JMCS-G-B	1
S3	2260002840	SKHLLFA010	1
S4*	2260002800	SW-167 (SKQT)	1
S5*	2260002800	SW-167 (SKQT)	1
*	2260002800	SW-167 (SKQT)	1
MP1*	8510017410	2893 VCO CASE	1
MP2	8510017420	2893 VCO COVER	1
MP3*	8510017610	OG-542925	1

[MAIN-A UNIT] (for F3160 series)

REF. NO.	ORDER NO.	DESCRIPTION	QTY.
J1*	6510025220	AXK540145J	1
J2*	6510025220	AXK540145J	1
J3*	6510025190	IMSA-9639S-20Y905	1
J4*	6510023970	20P3.5-JMCS-G-B	1
S3	2260002840	SKHLLFA010	1
S4*	2260002800	SW-167 (SKQT)	1
S5*	2260002800	SW-167 (SKQT)	1
S6*	2260002800	SW-167 (SKQT)	1
EP7†	-	UT-126H [F3160DT/DS] only	1
MP1*	8510017410	2893 VCO CASE	1
MP2	8510017420	2893 VCO COVER	1
MP3*	8510017610	OG-542925	1
MP4	8930070311	SPONGE (JE)-1 [F3160DT/DS] only	1
MP5	8930061120	SHIELD SPONGE (AA)	1

*: Refer to "BOARD LAYOUTS" for the location.

†: Optional product.

Screw abbreviations

B0, BT: Self-tapping
 PH: Pan head FT: Flat head
 ZK: Black SUS: Stainless
 NI-ZU: Nickel-Zinc

[RF UNIT]

REF. NO.	PARTS NO.	DESCRIPTION	QTY.
J601	6910017940	IMSA-9230B-1-05Z118-PT1	1
J602	6910017940	IMSA-9230B-1-05Z118-PT1	1
F601*	5210000970	ERBSE3R00U	1
MP601*	8510017600	OG-363050	1

[VR UNIT]

REF. NO.	PARTS NO.	DESCRIPTION	QTY.
J701*	6510024930	20RF-JMCS-G-1B-TF (N)	1
S701	2250000490	TP70TF5163 15.9F-2775	1
S702*	2230001060	EVQ-PUL 02K	1

[ACCESSORIES]

REF. NO.	PARTS NO.	DESCRIPTION	QTY.
EP1†	–	FA-SC55V-2	1
EP2†	–	BP-232N	1
MP1†	–	MB-94	1
MP2	8210021471	2803 SIDE PANEL-1	1
MP3	8810010430	SCREW TRUSS M3X5 SUS SSBC	1

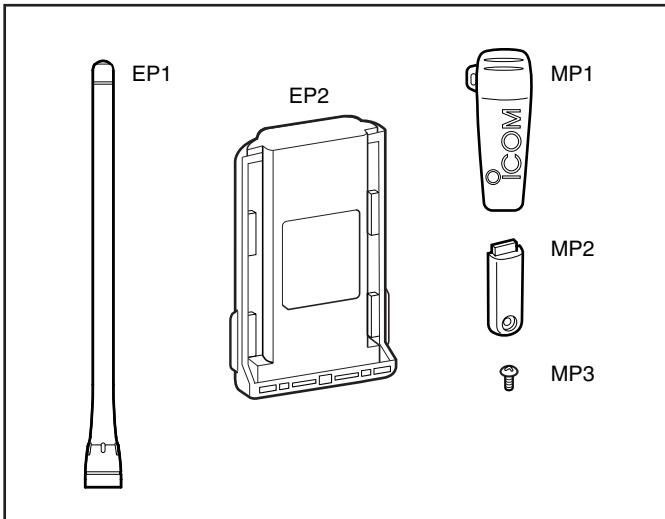

*: Refer to "BOARD LAYOUTS" for the location.

†: Optional product.

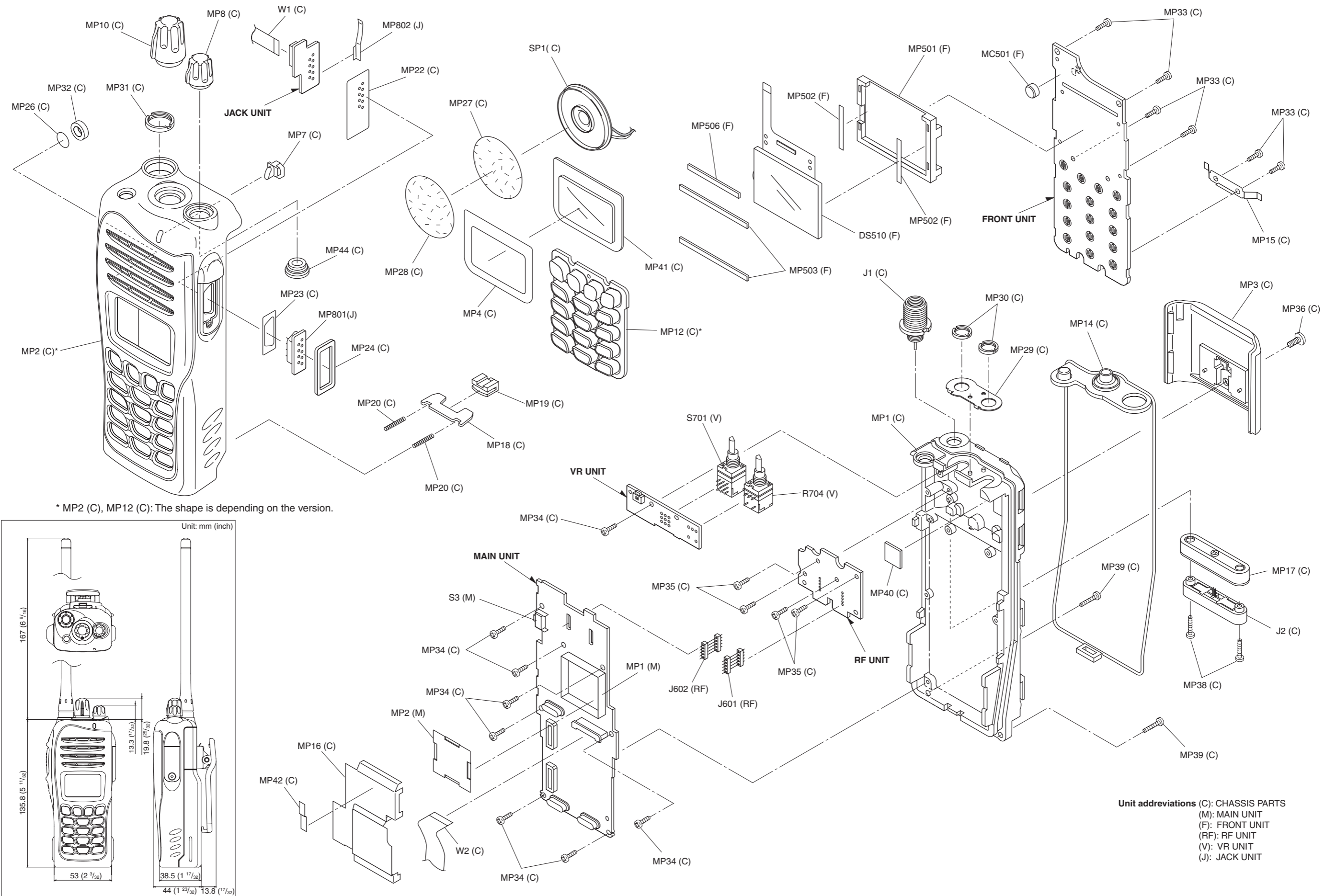

SECTION 9

BOARD LAYOUTS

• For F3060 series

• FRONT UNIT (TOP VIEW)

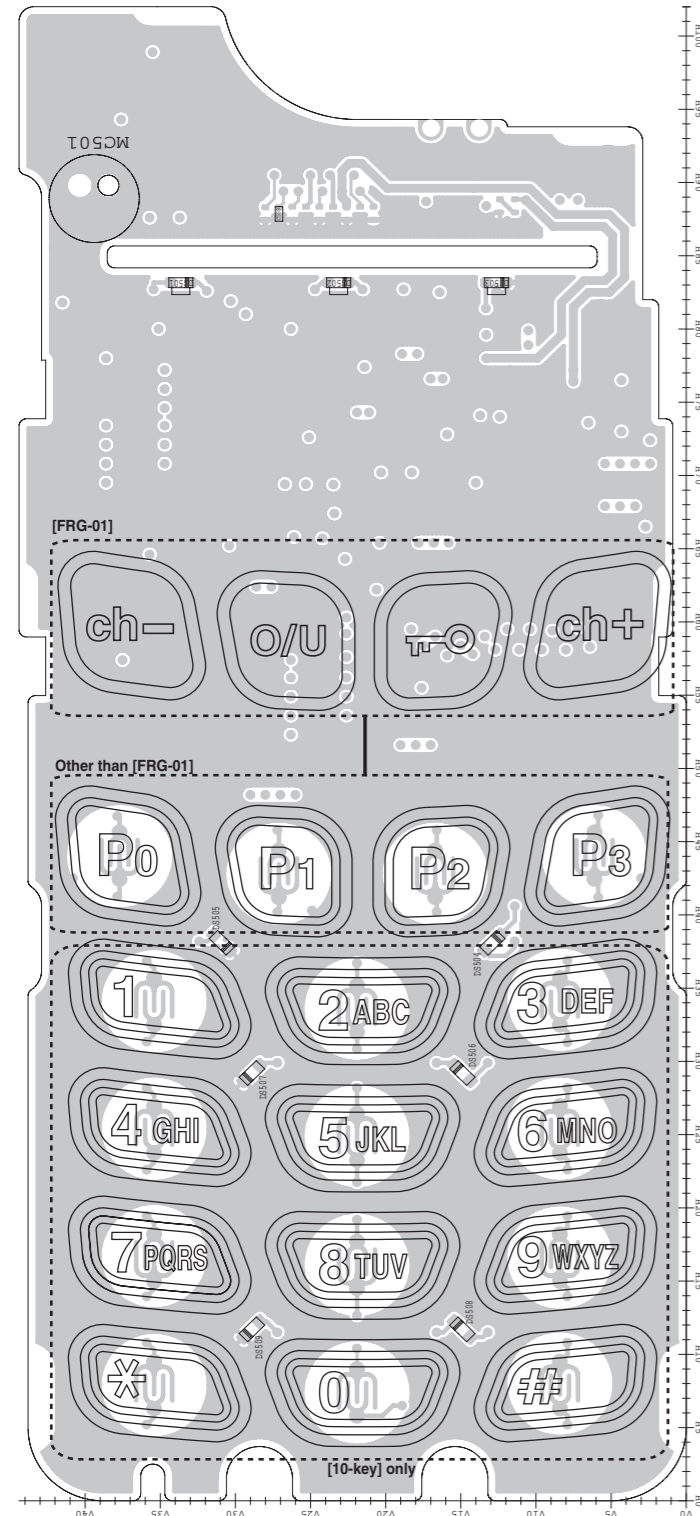

• MAIN UNIT (TOP VIEW)

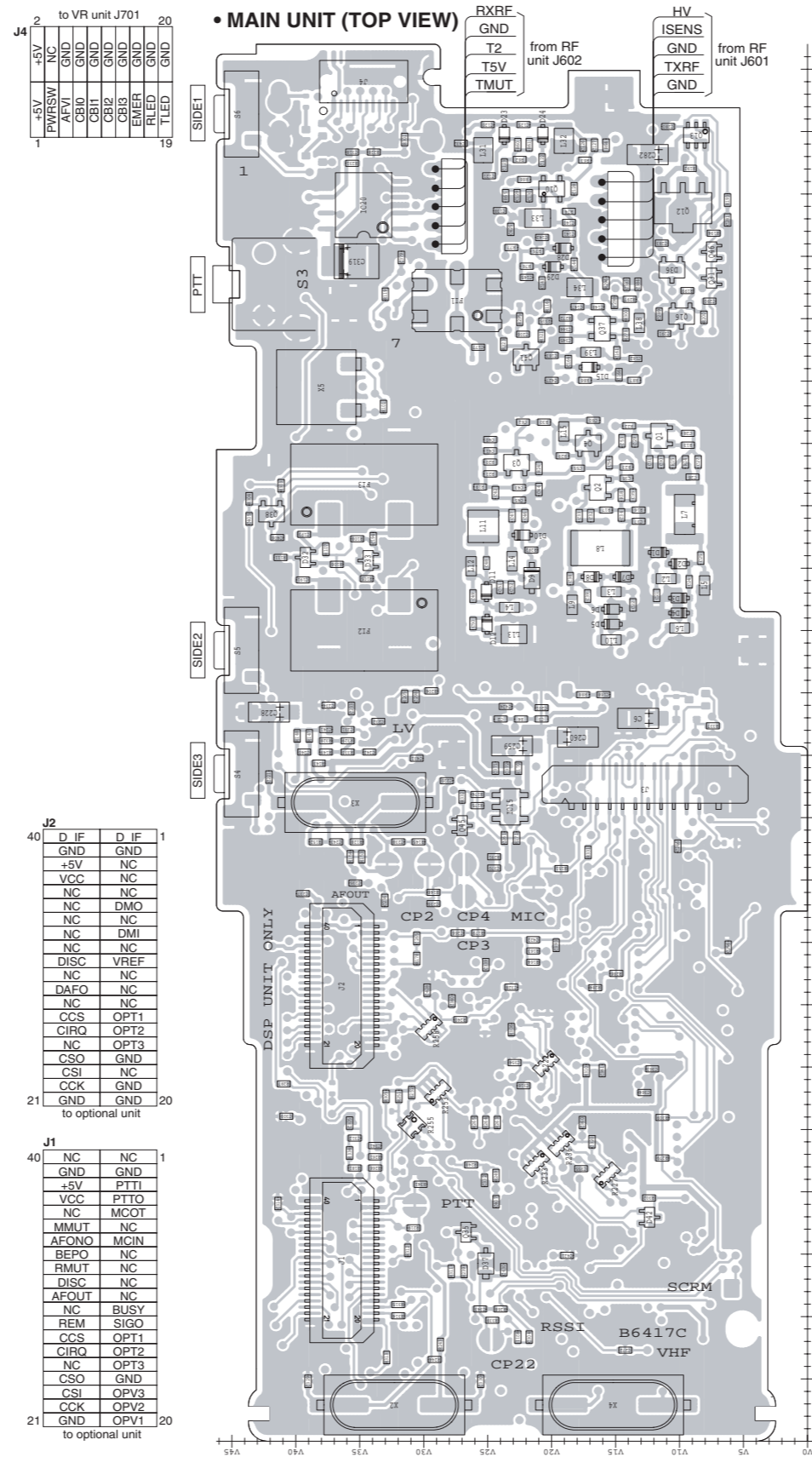

• RF UNIT (TOP VIEW)

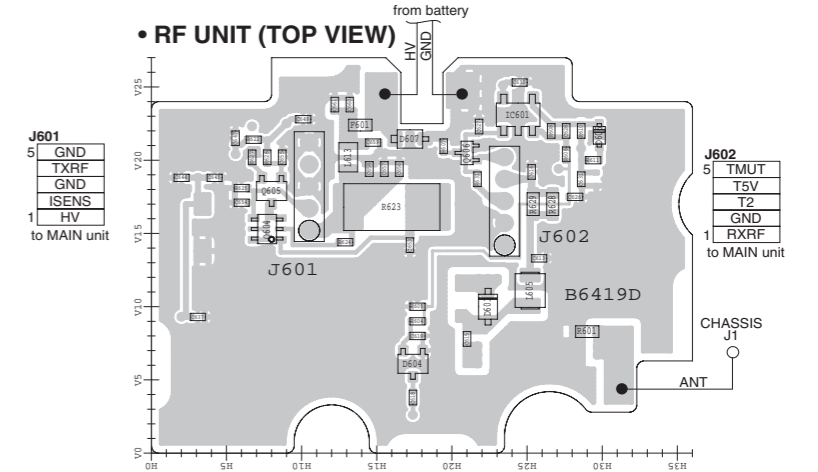

• JACK UNIT (TOP VIEW)

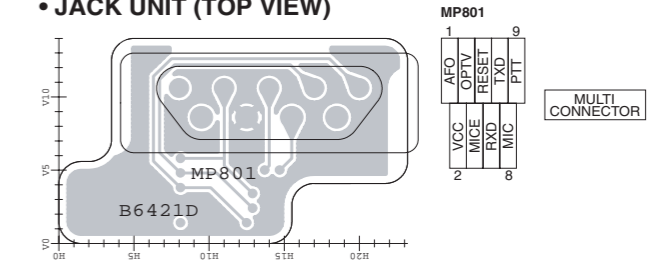

• VR UNIT (TOP VIEW)

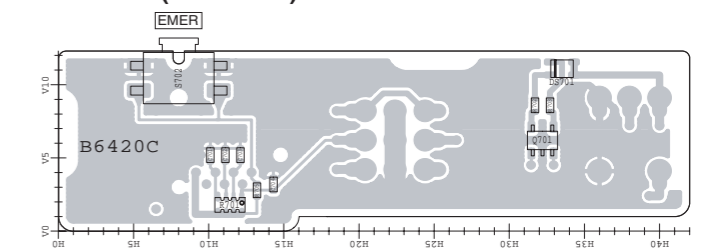

• VR-A UNIT (TOP VIEW) ([FRG-01] only)

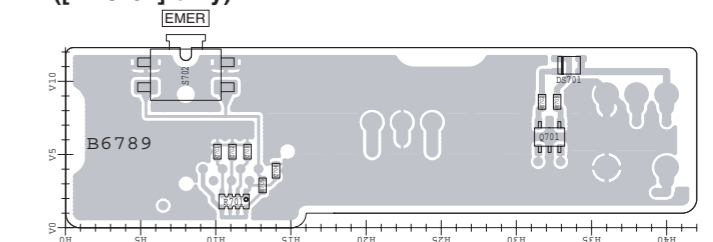

• BC-160 (TOP VIEW)

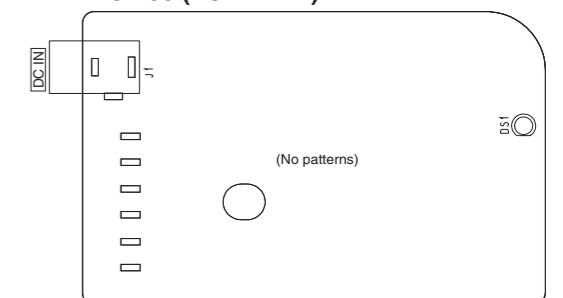

• RF UNIT (BOTTOM VIEW)

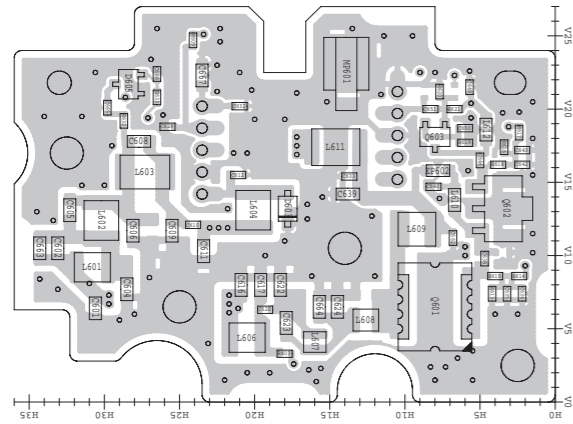

• JACK UNIT (BOTTOM VIEW)

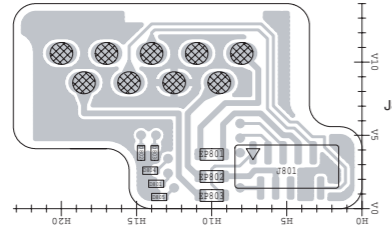

1	EPITT	to FRONT unit J503
2	EMIC	
3	VCC	
4	NC	
5	NC	
6	NC	
7	NC	
8	RES	
9	RES	
10	RES	

• VR UNIT (BOTTOM VIEW)

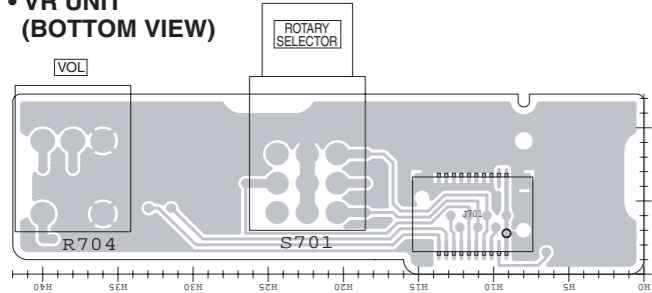

20	GND	to MAIN unit J4
19	TLED	
18	RLED	
17	EMER	
16	CB12	
15	CB12	
14	CB12	
13	CB10	
12	CB10	
11	AFVI	
10	PWRSW	
9	NC	
8	+5V	
7	+5V	
6	NC	
5	NC	
4	NC	
3	NC	
2	+5V	

• VR-A UNIT (BOTTOM VIEW) ([FRG-01] only)

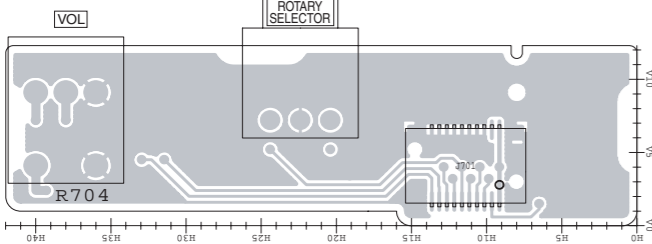

20	GND	to MAIN unit J4
19	TLED	
18	RLED	
17	EMER	
16	CB12	
15	CB12	
14	CB12	
13	CB10	
12	CB10	
11	AFVI	
10	PWRSW	
9	NC	
8	+5V	
7	+5V	
6	NC	
5	NC	
4	NC	
3	NC	
2	+5V	

• BC-160 (BOTTOM VIEW)

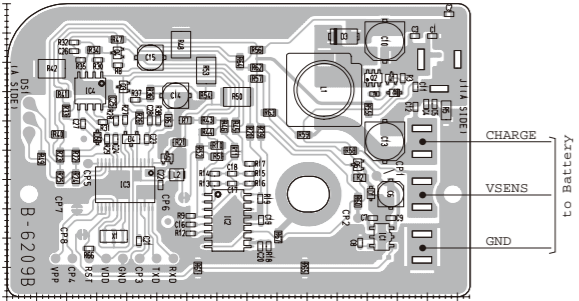

• MAIN UNIT (BOTTOM VIEW)

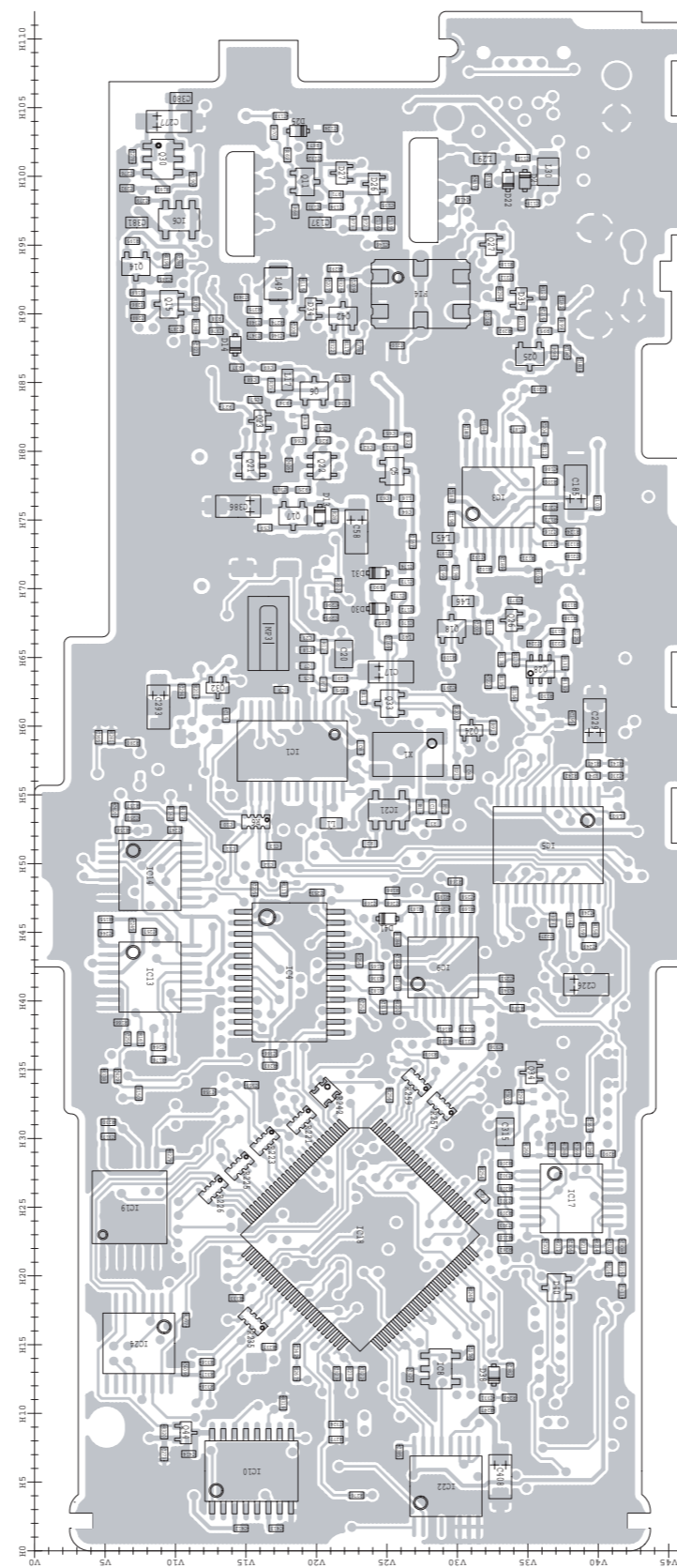

• FRONT UNIT (BOTTOM VIEW)

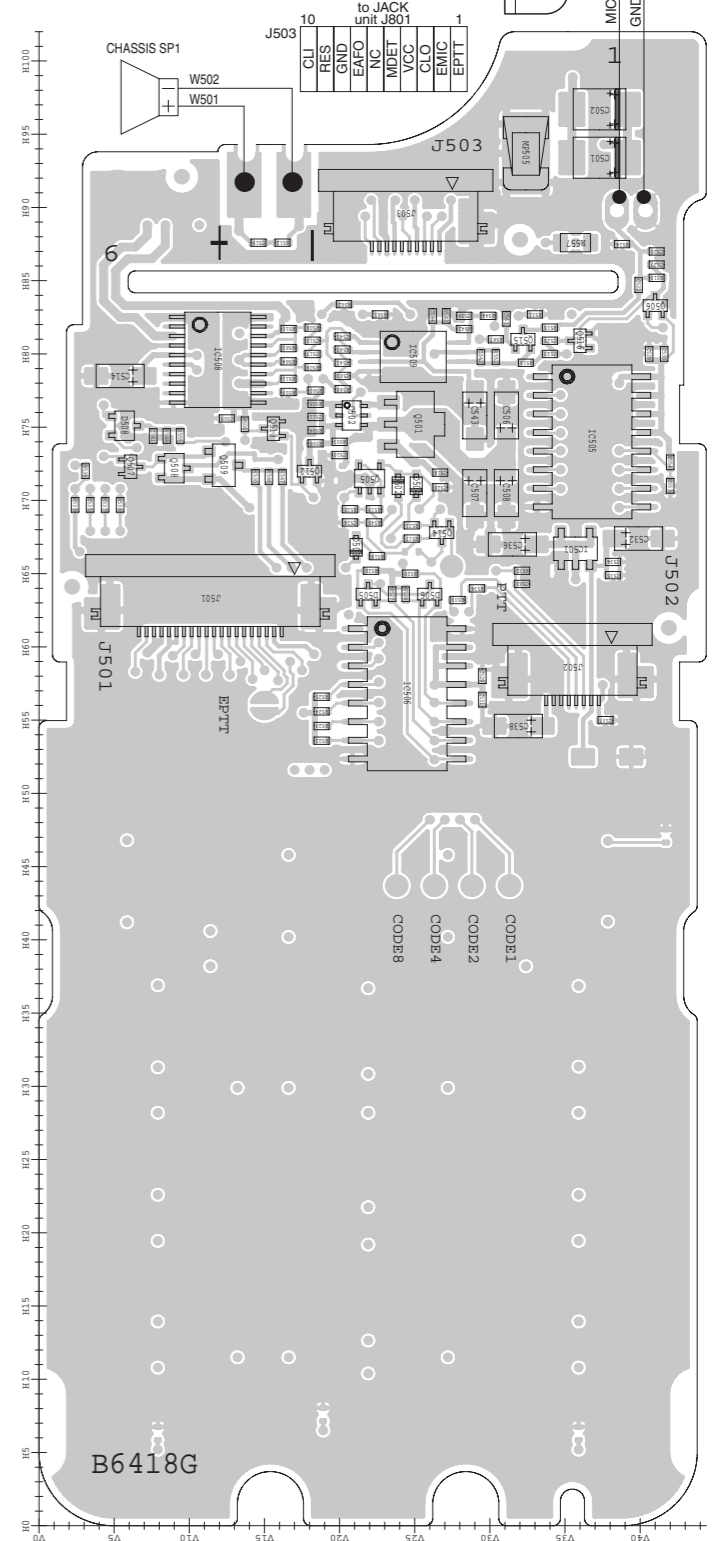

The combination of this side and the bottom side shows the board layout in the same configuration as the actual P.C.Board.

20	GND	to MAIN unit J3
19	MDET	
18	VCC	
17	VCC	
16	VCC	
15	VCC	
14	VCC	
13	VCC	
12	VCC	
11	VCC	
10	VCC	
9	VCC	
8	VCC	
7	VCC	
6	VCC	
5	VCC	
4	VCC	
3	VCC	
2	VCC	
1	GND	

1	AG+	
2	AG+	
3	AG+	
4	AG+	
5	AG+	
6	AG+	
7	AG+	
8	AG+	
9	AG+	
10	AG+	
11	AG+	
12	AG+	
13	AG+	
14	AG+	
15	AG+	
16	AG+	
17	AG+	
18	AG+	
19	AG+	
20	AG+	

• FRONT UNIT (TOP VIEW)

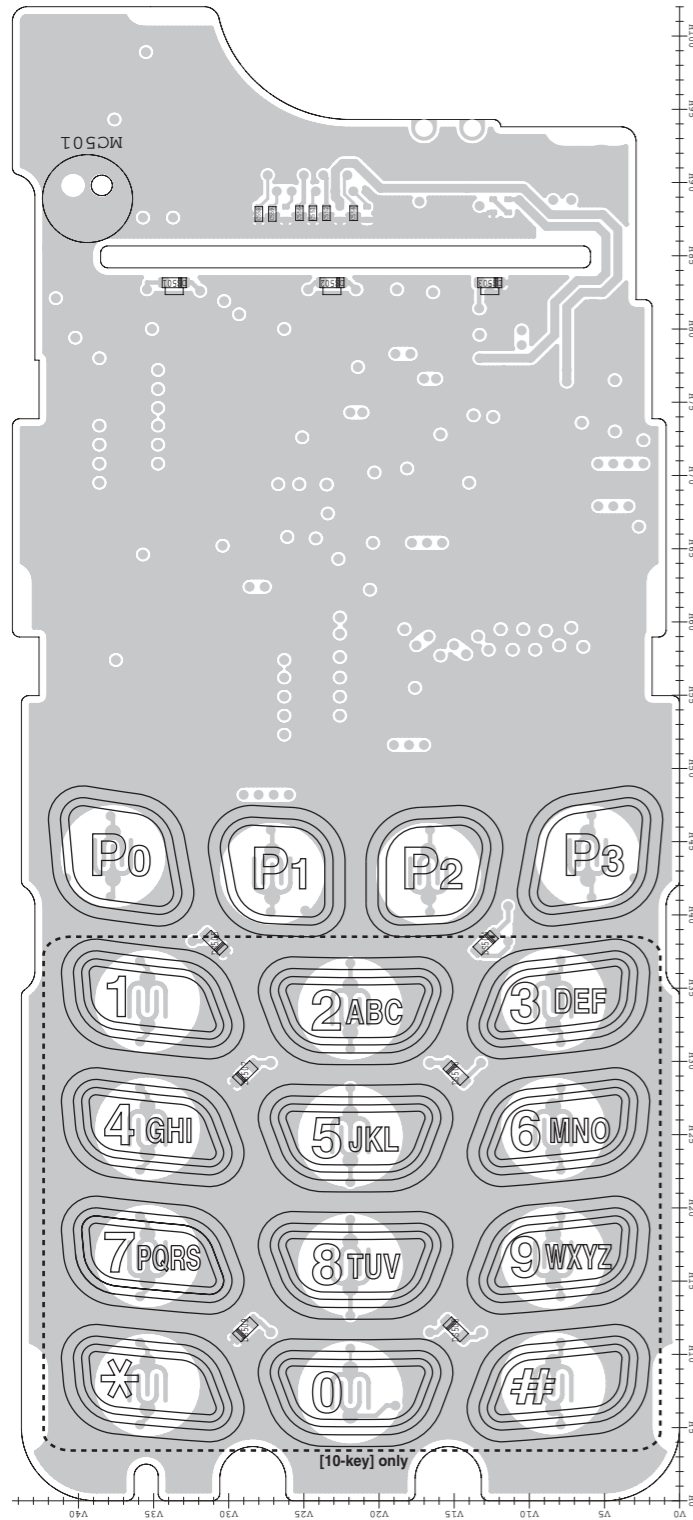

J4 to VR unit J701

2	+5V	NC	GND	GND	20
1	PWRSM	AFVI	CB10	CB11	19
	CB12	CB13	EMER	TLED	
	GND	GND	GND	GND	

J2 to optional unit

40	D IF	D IF	1
	GND	GND	
	+5V	NC	
	VCC	NC	
	NC	NC	
	NC	DMO	
	NC	NC	
	NC	DMI	
	NC	NC	
	DISC	VREF	
	NC	NC	
	DAFO	NC	
	NC	NC	
	CCS	OPT1	
	CIRQ	OPT2	
	NC	OPT3	
	CSO	GND	
	CSI	NC	
	CCK	GND	
21	GND	GND	20

J1 to optional unit

40	NC	NC	1
	GND	GND	
	+5V	PTTI	
	VCC	PTTO	
	NC	MCOT	
	MMUT	NC	
	AFONO	MCIN	
	BEPO	NC	
	RMUT	NC	
	DISC	NC	
	AFOUT	NC	
	NC	BUSY	
	REM	SIGO	
	CCS	OPT1	
	CIRQ	OPT2	
	NC	OPT3	
	CSO	GND	
	CSI	OPV3	
	CCK	OPV2	
21	GND	OPV1	20

• MAIN UNIT (TOP VIEW)

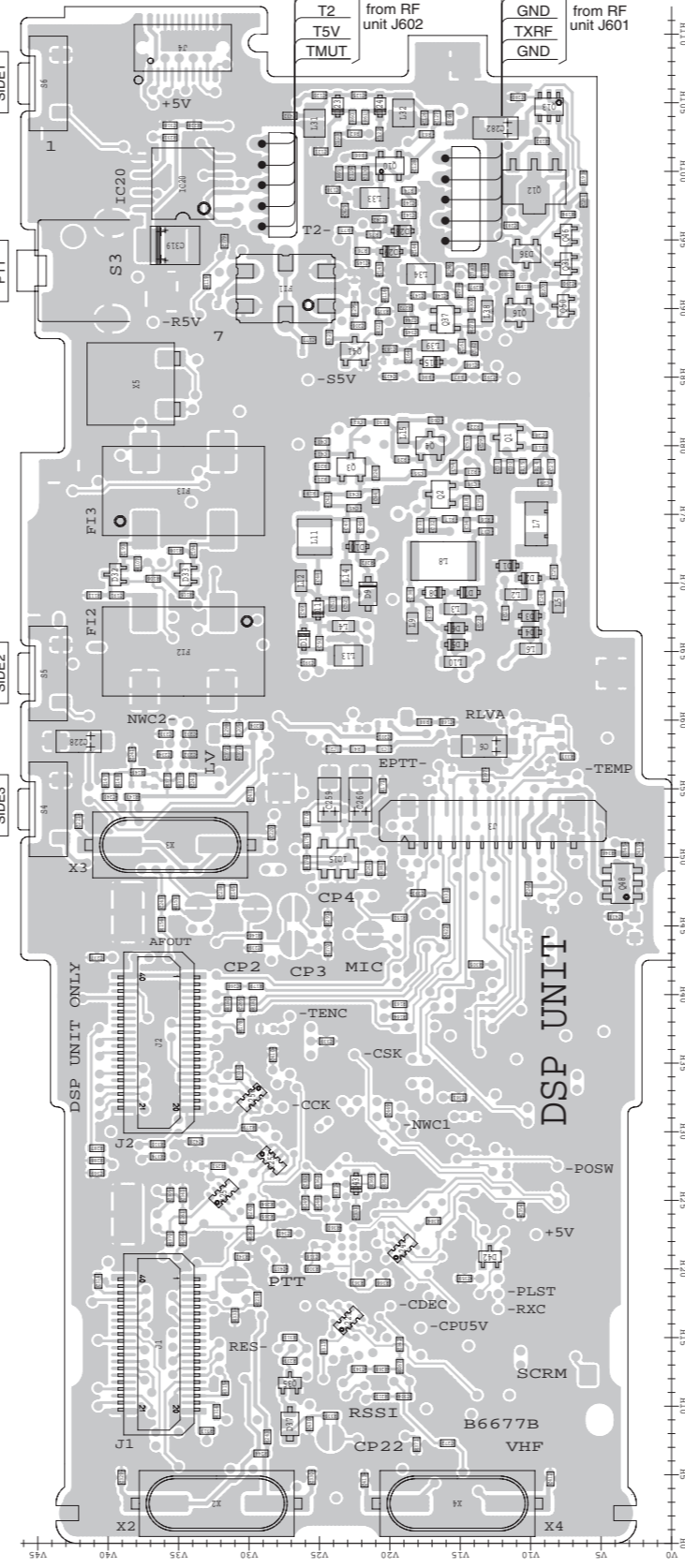

J3 to FRONT unit J501

1	GND	MCIN	AF	EPIT	LRES	AFONO	AFONO	CLI	KR	PTTI	PITTSW	FSDA	FSCL	RES	CLO	+5V	VCC	VCC	MOET	GND	20
---	-----	------	----	------	------	-------	-------	-----	----	------	--------	------	------	-----	-----	-----	-----	-----	------	-----	----

• RF UNIT (TOP VIEW)

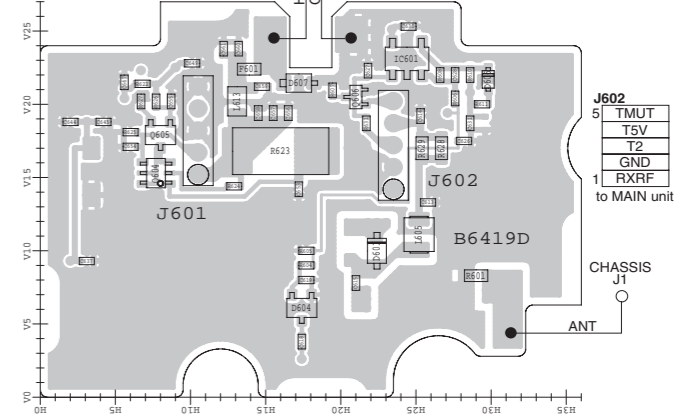

J601 to MAIN unit

5	GND	TXRF	GND	ISENS	HV	1
---	-----	------	-----	-------	----	---

J602 to MAIN unit

5	TMUT	T5V	T2	GND	RXRF	1
---	------	-----	----	-----	------	---

• JACK UNIT (TOP VIEW)

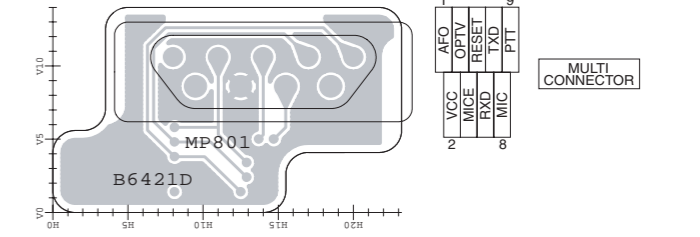

MP801 MULTI CONNECTOR

1	AFO	OPTV	RESET	RXD	TXD	PTT	9
2	VCC	MIC	RXD	TXD	MIC		8

• VR UNIT (TOP VIEW)

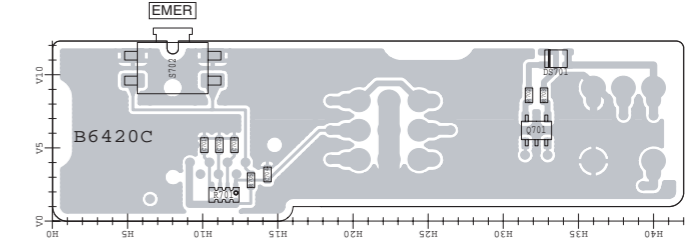

• BC-160 (TOP VIEW)

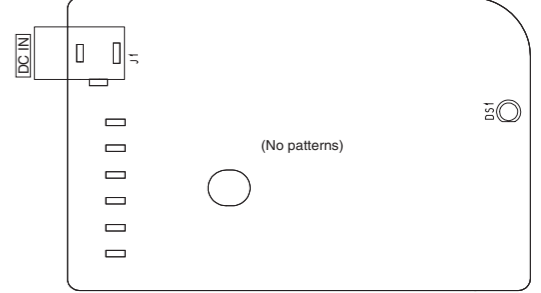

The combination of this side and the bottom side shows the board layout in the same configuration as the actual P.C.Board.

The combination of this side and the bottom side shows the board layout in the same configuration as the actual P.C.Board.

• RF UNIT (BOTTOM VIEW)

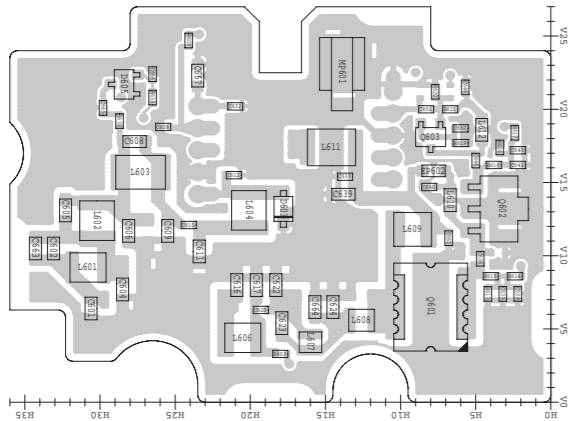

• JACK UNIT (BOTTOM VIEW)

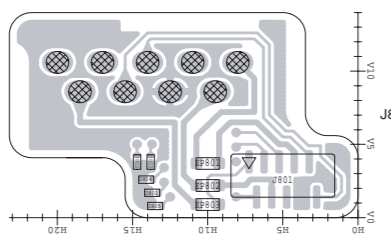

1	EPTT	to FRONT unit J503
2	EMIC	
3	VCC	
4	NC	
5	GND	
6	EAFO	
7	RES	
8	CLI	
9		
10		

• VR UNIT (BOTTOM VIEW)

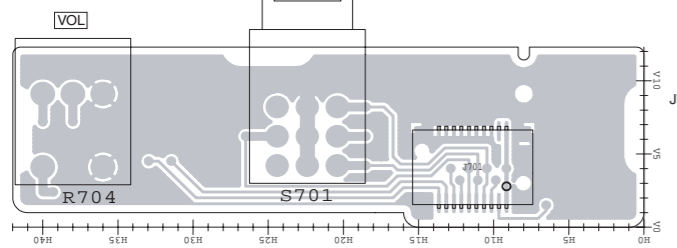

1	+5V	to MAIN unit J4
2	NC	
3	GND	
4	FMRSW	
5	AFV	
6	CB0	
7	CB1	
8	CB2	
9	CB3	
10	CB4	
11	CB5	
12	CB6	
13	CB7	
14	CB8	
15	CB9	
16	CB10	
17	CB11	
18	CB12	
19	TLCD	
20	GND	

• BC-160 (BOTTOM VIEW)

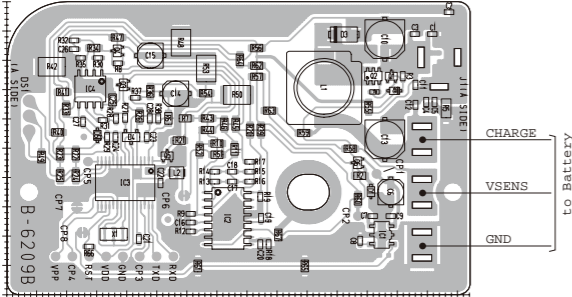

• MAIN UNIT (BOTTOM VIEW)

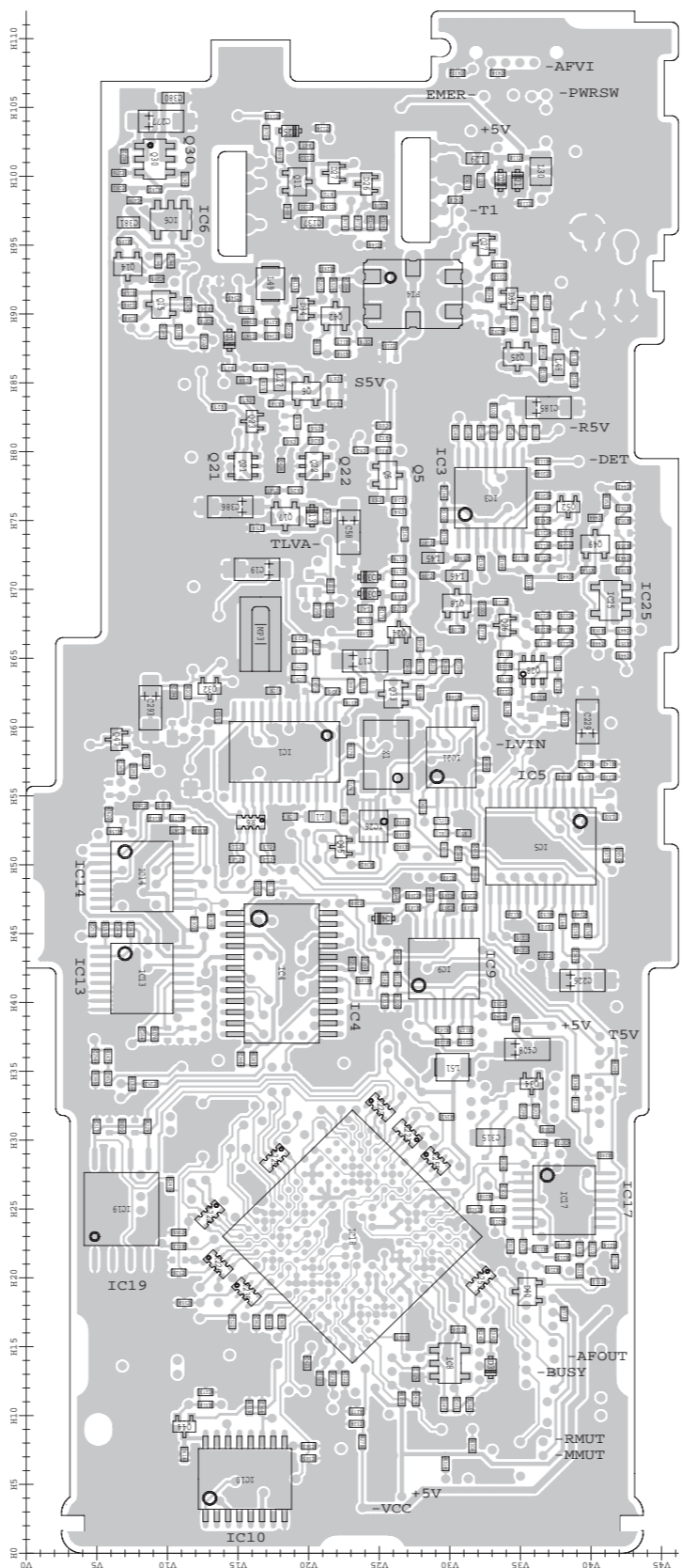

• FRONT UNIT (BOTTOM VIEW)

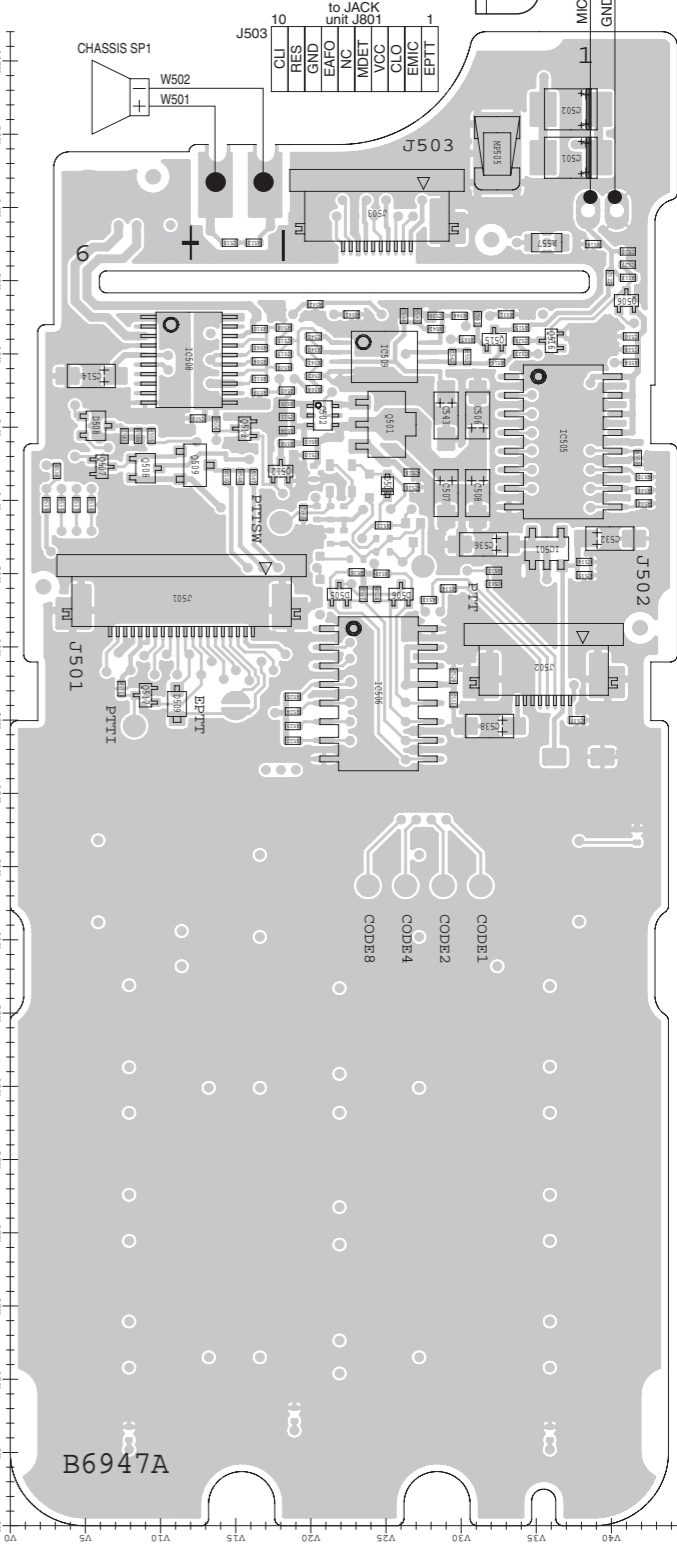

1	GND	to MAIN unit J3
2	MCIN	
3	AF	
4	EPIT	
5	URES	
6	AFONO	
7	CLI	
8	RR	
9	PITISW	
10	FSDA	
11	FSC	
12	RES	
13	GND	
14	AS+	
15	VCC	
16	VCC	
17	MDET	
18	GND	
19	AS+	
20	GND	

1	AS+	to LCD
2	RES	
3	RES	
4	RES	
5	RES	
6	RES	
7	RES	
8	GND	
9	GND	
10	GND	

SECTION 10

BLOCK DIAGRAM

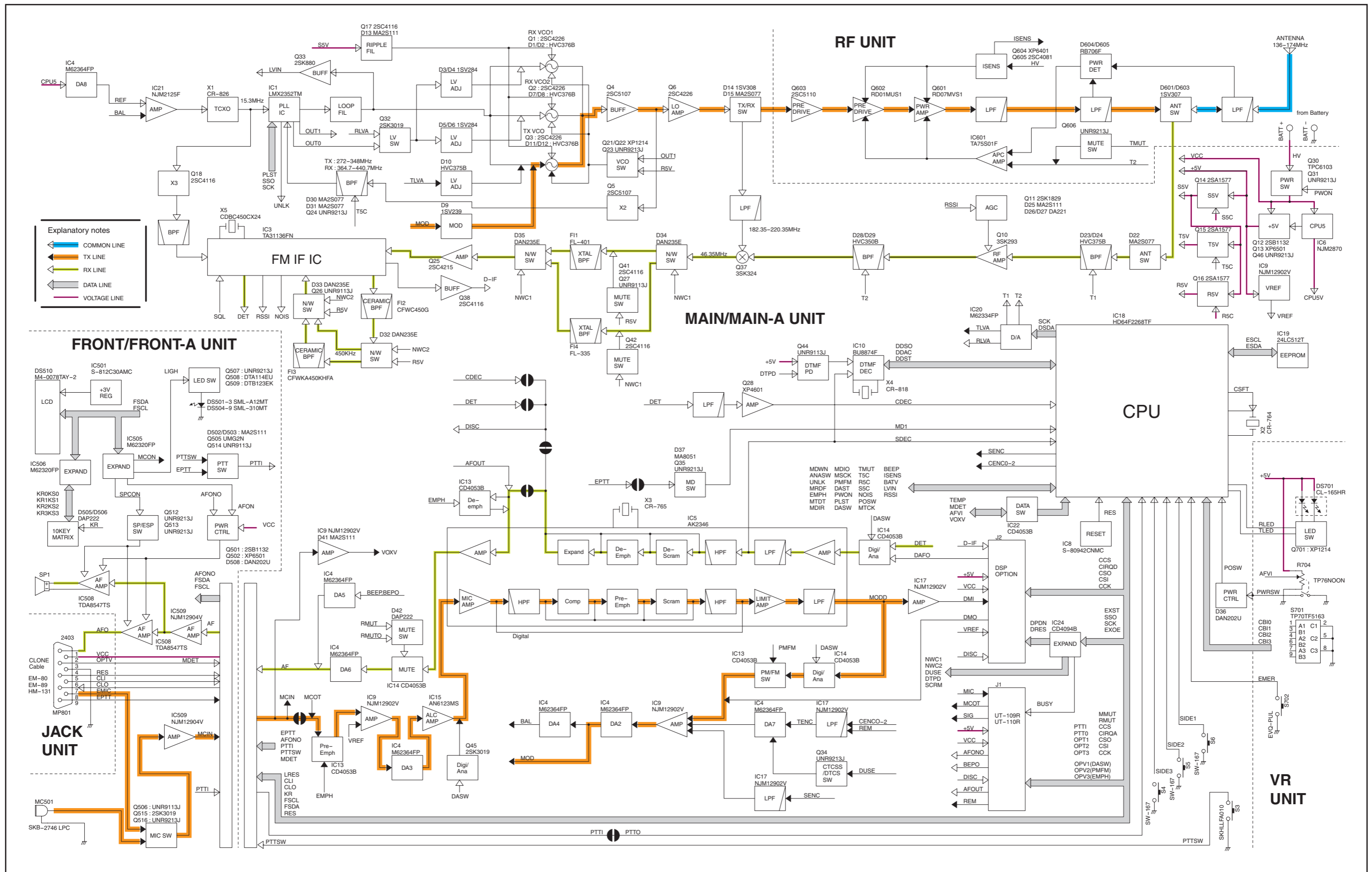

SECTION 11

VOLTAGE DIAGRAM

• FRONT UNIT (for F3060 series)

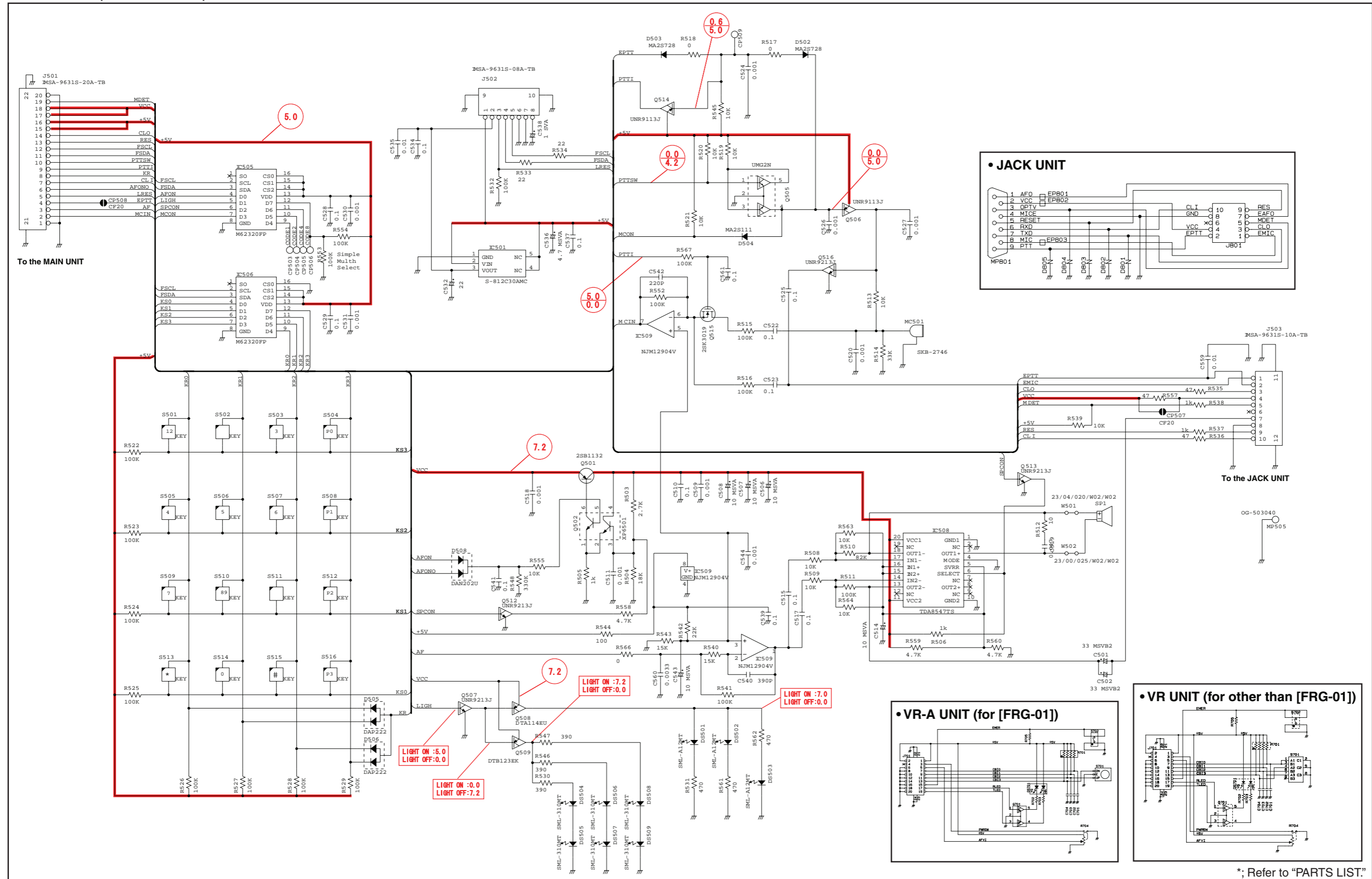

*; Refer to "PARTS LIST."

• FRONT-A UNIT (for F3160 series)

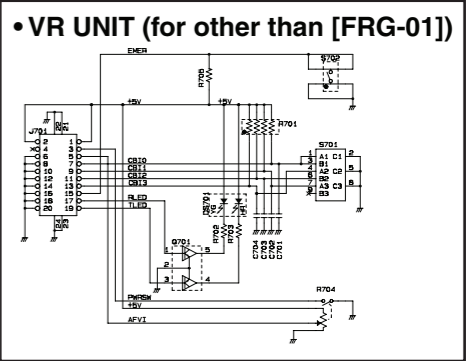
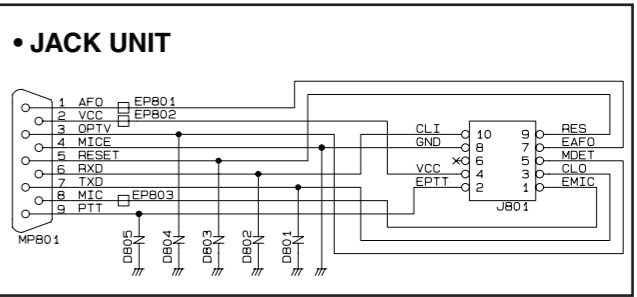
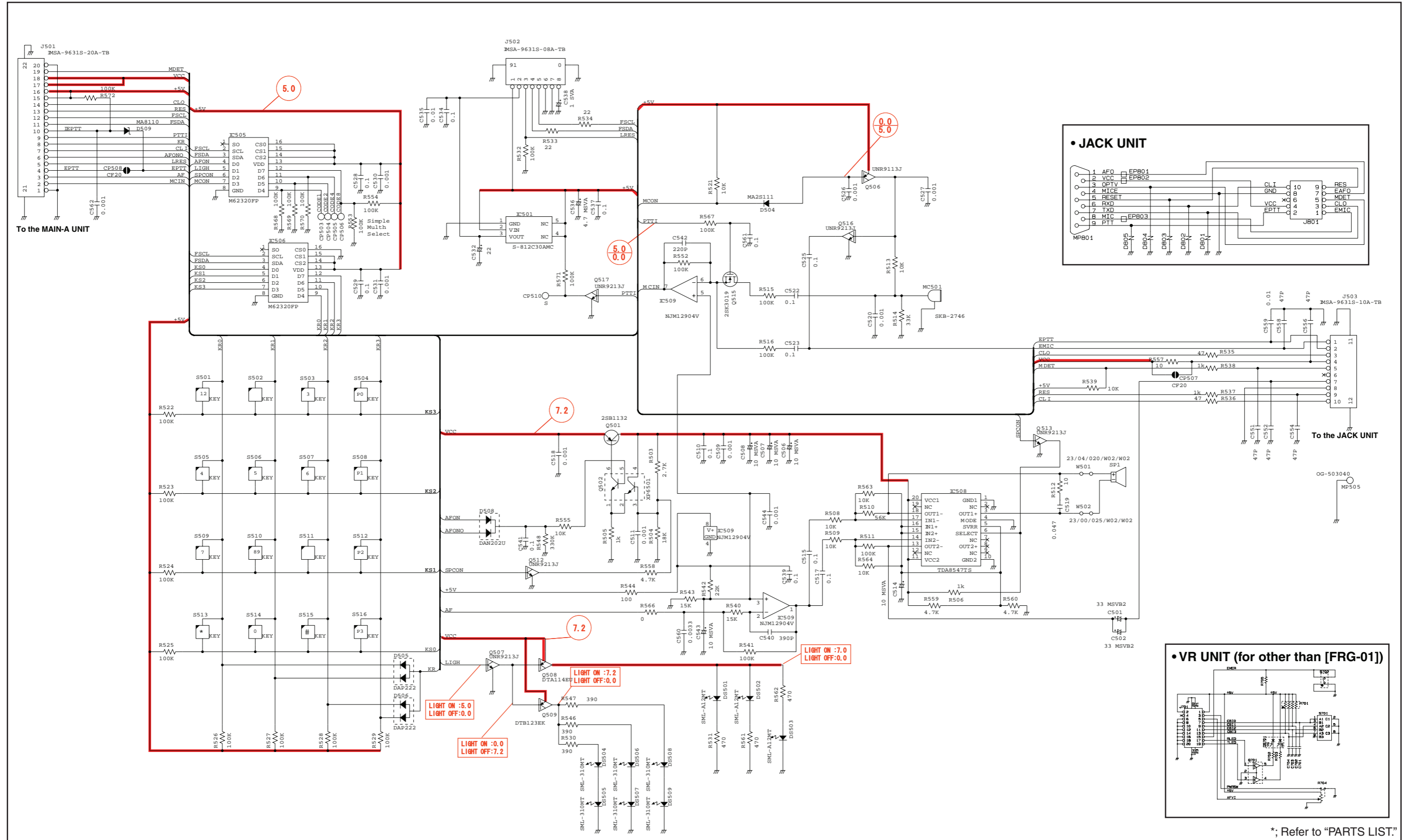

*; Refer to "PARTS LIST."

• MAIN UNIT (for F3060 series)

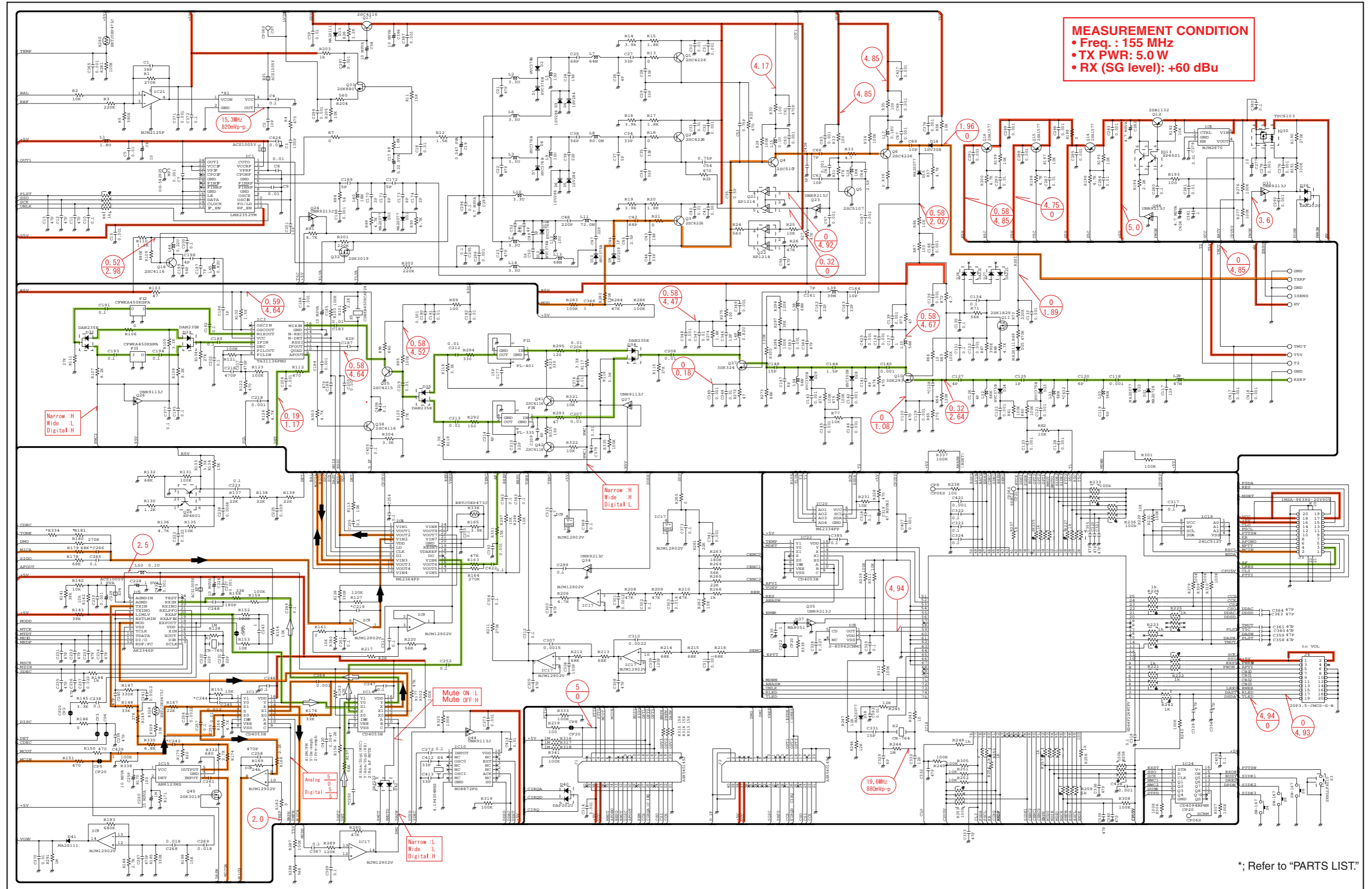

MEASUREMENT CONDITION
• Freq. : 155 MHz
• TX PWR: 5.0 W
• RX (SG level): +60 dBu

Narrow :H
Wide :L
Digital:H

Narrow :H
Wide :H
Digital:L

Analog :G
Digital :G

Narrow :L
Wide :H
Digital:H

*; Refer to "PARTS LIST."

• MAIN-A UNIT (for F3160 series)

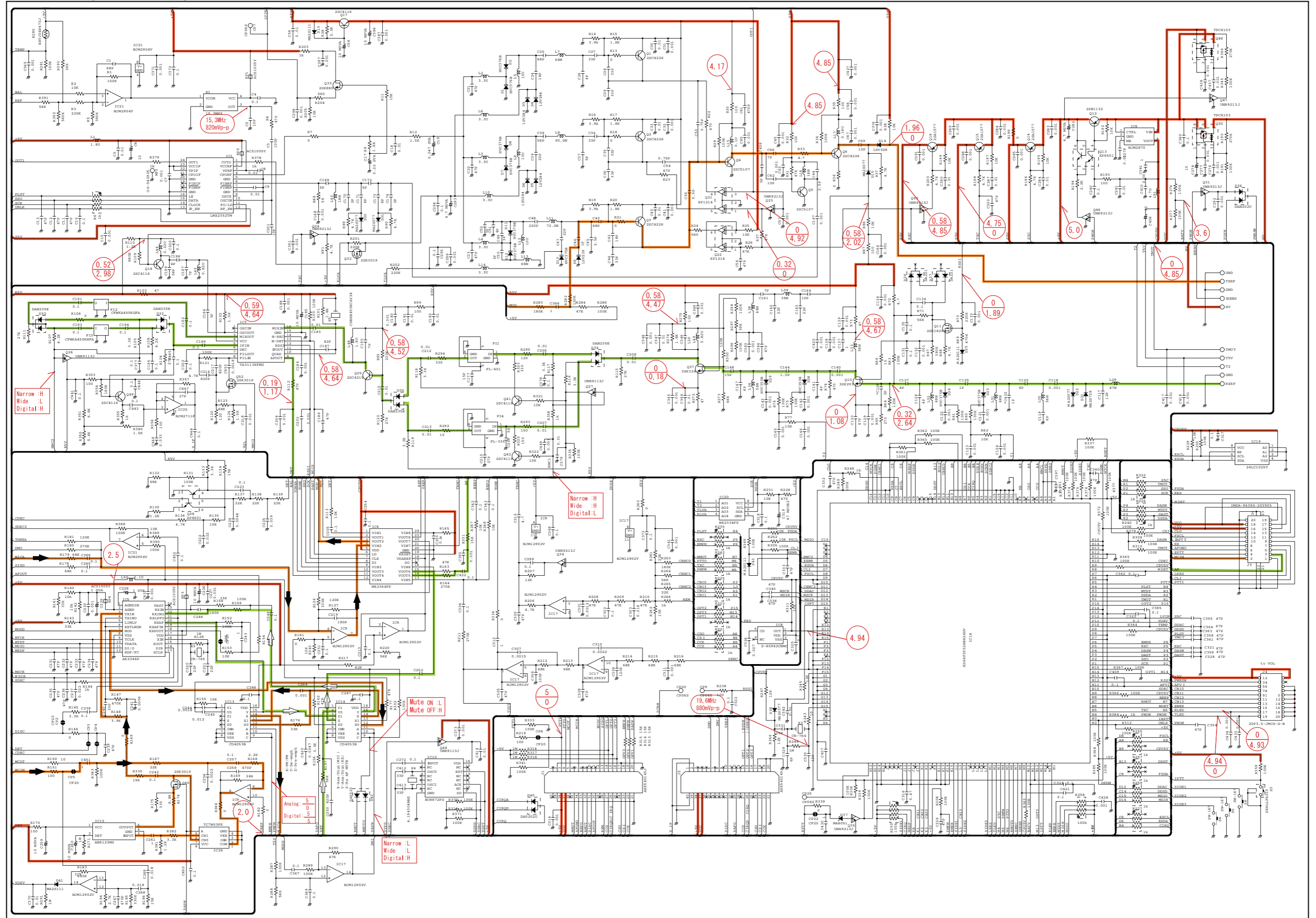

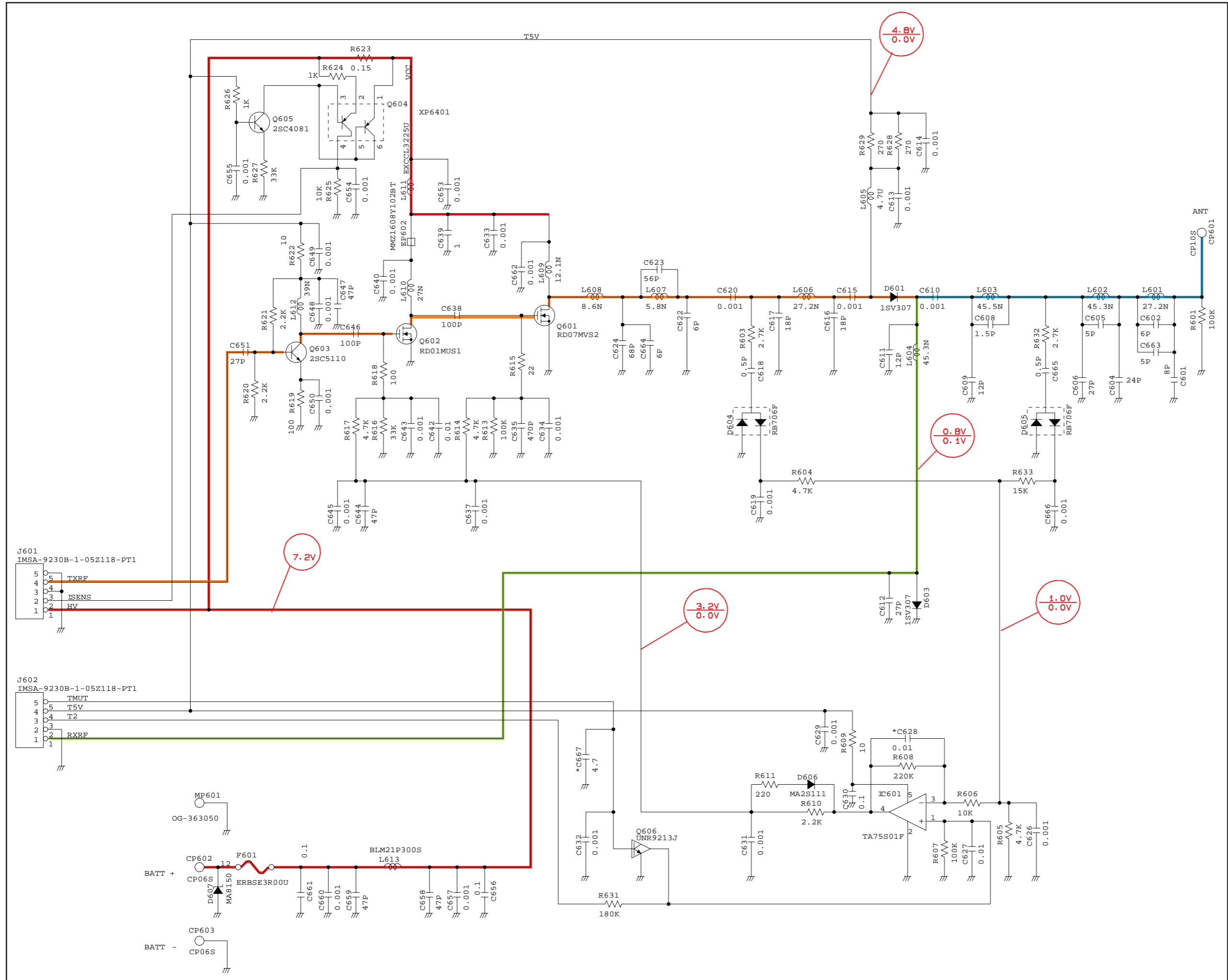

SECTION 12

BC-160 (Optional)

[CHASSIS PARTS]

REF. NO.	ORDER NO.	DESCRIPTION	QTY.
MP1	8010019750	2830 case	1
MP2	8110008220	2830 cover	1
MP3	8930039620	Leg cushion (A)	2
MP4	8810008630	Screw PH BT M3 x 6 NI-ZU	1

[MAIN UNIT]

REF. NO.	ORDER NO.	DESCRIPTION	QTY.
J1	6510023070	Connector HEC2305-01-250	1
DS1	5040002740	LED RT3-03HRYG	1
MP1	8930064410	2830 TERMINAL	3

[ACCESSORIES]

REF. NO.	ORDER NO.	DESCRIPTION	QTY.
EP1	Optional product	Charger BC-145E	[EUR] 1
	Optional product	Charger BC-145UK	[UK] 1

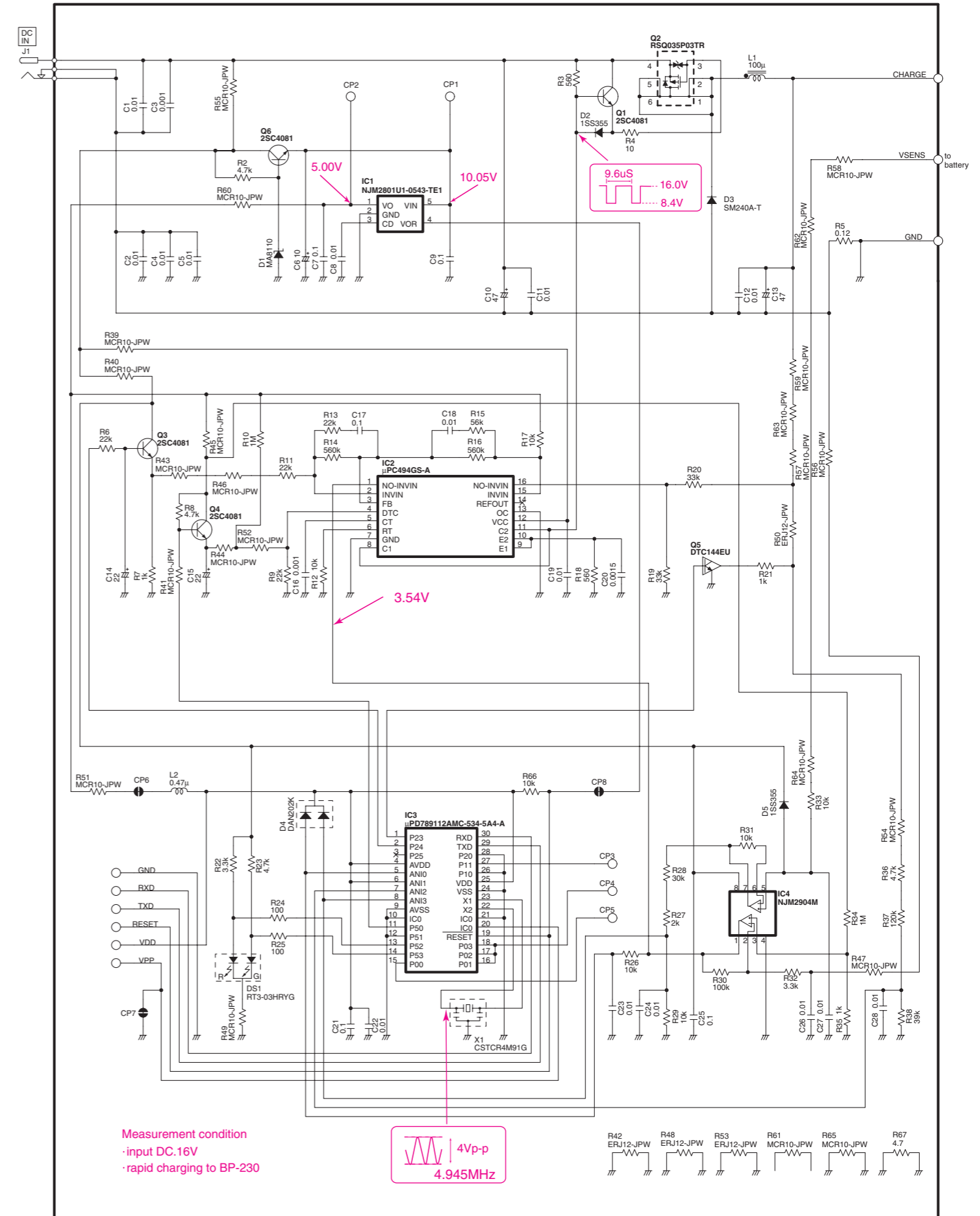
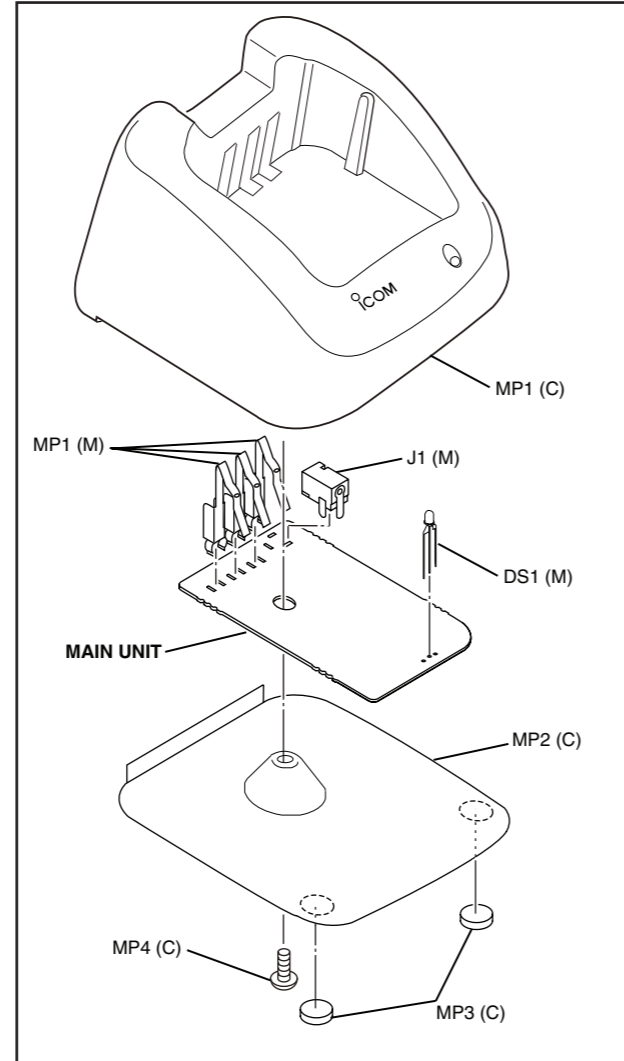

Icom Inc.

1-1-32, Kamiminami, Hirano-ku, Osaka 547-0003, Japan
Phone : +81 (06) 6793 5302
Fax : +81 (06) 6793 0013
URL : <http://www.icom.co.jp/world/index.html>

Icom America Inc.

<Corporate Headquarters>
2380 116th Avenue N.E., Bellevue, WA 98004, U.S.A.
Phone : +1 (425) 454-8155 Fax : +1 (425) 454-1509
URL : <http://www.icomamerica.com>
E-mail : sales@icomamerica.com
<Customer Service>
Phone : +1 (425) 454-7619

Icom Canada

Glenwood Centre #150-6165
Highway 17 Delta, B.C., V4K 5B8, Canada
Phone : +1 (604) 952-4266 Fax : +1 (604) 952-0090
URL : <http://www.icomcanada.com>
E-mail : info@icomcanada.com

Icom (Australia) Pty. Ltd.

Unit 1 / 103 Garden Road, Clayton VIC 3168 Australia
Phone : +61 (03) 9549-7500 Fax : +61 (03) 9549-7505
URL : <http://www.icom.net.au>
E-mail : sales@icom.net.au

Icom New Zealand

146A Harris Road, East Tamaki,
Auckland, New Zealand
Phone : +64 (09) 274 4062 Fax : +64 (09) 274 4708
URL : <http://www.icom.co.nz>
E-mail : inquiries@icom.co.nz

Beijing Icom Ltd.

10C07, Long silver Mansion, No.88, Yong Ding
Road, Haidian District, Beijing, 100039, China
Phone : +86 (010) 5889 5391/5392/5393
Fax : +86 (010) 5889 5395
E-mail : bjicom@bjicom.com
URL : <http://www.bjicom.com>

Icom (Europe) GmbH

Communication Equipment
Himmelgeister Str. 100, D-40225 Düsseldorf, Germany
Phone : +49 (0211) 346047 Fax : +49 (0211) 333639
URL : <http://www.icomeurope.com>
E-mail : info@icomeurope.com

Icom Spain S.L

Ctra. Rubi, No. 88 Bajos A 08174, Sant Cugat del Valles, Barcelona, Spain
Phone : +34 (93) 590 26 70 Fax : +34 (93) 589 04 46
URL : <http://www.icomspain.com>
E-mail : icom@icomspain.com

Icom (UK) Ltd.

Unit 9, Sea St., Herne Bay, Kent, CT6 8LD, U.K.
Phone : +44 (01227) 741741 Fax : +44 (01227) 741742
URL : <http://www.icomuk.co.uk>
E-mail : info@icomuk.co.uk

Icom France s.a.s.

Zac de la Plaine
1 Rue Brindejonc des Moulinais BP 5804
31505 Toulouse Cedex, France
Phone : +33 (5) 61 36 03 03 Fax : +33 (5) 61 36 03 00
URL : <http://www.icom-france.com>
E-mail : icom@icom-france.com

Asia Icom Inc.

6F No.68, Sec. 1 Cheng-Teh Road, Taipei, Taiwan, R.O.C.
Phone : +886 (02) 2559 1899 Fax : +886 (02) 2559 1874
URL : <http://www.asia-icom.com>
E-mail : sales@asia-icom.com

Icom Polska

81-850 Sopot, ul. 3 Maja 54, Poland
Phone : +48 (58) 550 7135 Fax : +48 (58) 551 0484
E-mail : icompolaska@icompolaska.com.pl

Count on us!

Icom Inc.

1-1-32, Kamiminami, Hirano-ku, Osaka 547-0003, Japan

S-14223HZ-C1-②
© 2006–2008 Icom Inc.